

**HF**  
Halogen Free

REV.	ECN NO.	LOCATION	DESCRIPTION	DATE	DESIGN
A1				2/14'20	Wanglie
A2				2/19'20	Wanglie
A3			Update P/N List	03/26'20	Cay Zhao
A4			Change packing tray	01/10'21	ZC.XE

- NOTES:**
- PRODUCT MUST MEET CONTROLLED SUBSTANCES SPEC. ROHS 2.0
  - 1. MATERIAL:**
    - 1.1 HOUSING: NYLON , UL94V-0; COLOR: SEE TABLE.
    - 1.2 EXTRACTOR: NYLON ,UL94V-0;COLOR: SEE TABLE.
    - 1.3 CONTACT: COPPER ALLOY .
    - 1.4 FORK LOCK: STAINLESS STEEL.
  - 2. FINISH:**
    - 2.1 CONTACT:
      - GOLD PLATING(SEE TABLE.) ON CONTACT AREA.
      - 2.0um[80u"] MIN. MATTE-TIN PALTING ON SOLDER TAIL AREA.
      - 2.25um[90u"] MIN. NICKEL ON CONTACT AREA,
      - 1.27um[50u"] MIN. NICKEL ON OTHER AREA.
    - 2.2 SOLDER TAB & SMT PEG:
      - MATTE TIN PALTING 80u"Min ON SOLDER TAIL AREA.
      - 30u" MIN. NICKEL UNDERPLATING OVERALL.
  - 3. REFLOW SOLDER CAPABLE TO 260 °C MAX. 10S.**

568Q14-009H	G/F	BLACK	WHITE	2 SOLDER TABS AT BOTH ENDS AND 1 SMT PEG IN THE MIDDLE
568Q14-008H	G/F	WHITE	WHITE	
568Q14-007H	G/F	BLACK	BLACK	
568Q14-006H	Au15u"	BLACK	WHITE	
568Q14-005H	Au15u"	WHITE	WHITE	
568Q14-004H	Au15u"	BLACK	BLACK	
568Q14-003H	Au30u"	BLACK	WHITE	
568Q14-002H	Au30u"	WHITE	WHITE	
568Q14-001H	Au30u"	BLACK	BLACK	
PART NUMBER	PLATING	HOUSING COLOR	EXTRACTOR COLOR	

**DEREN**  
SHENZHEN DEREN ELECTRONIC CO., LTD

CUSTOMER DRAWING	DATE	TITLE: DDR4 288P BIG EAR MID PEG SMT TYPE NO CAP
DESIGN: Cay Zhao	05/15'20	P/N: SEE TABLE
CHECK: Bill Lin	05/15'20	SHEET: 1/3
APPROVAL: Smark Huo	05/15'20	SCALE: 1:1 UNIT: mm

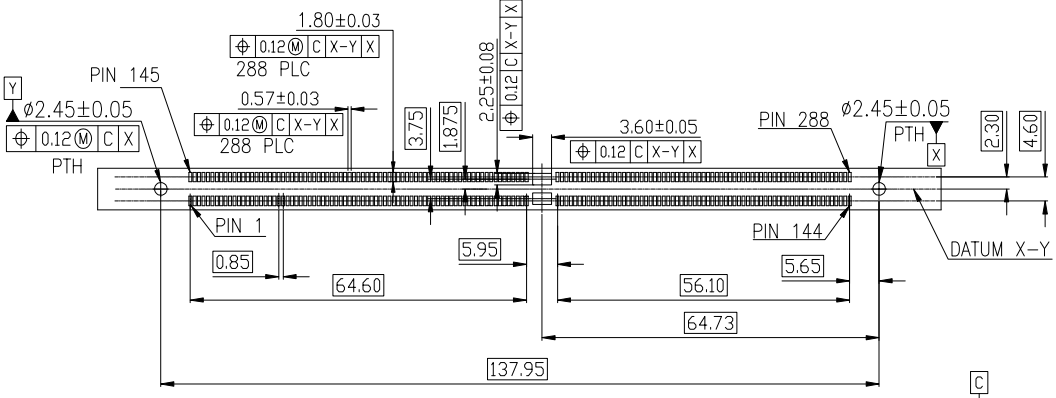
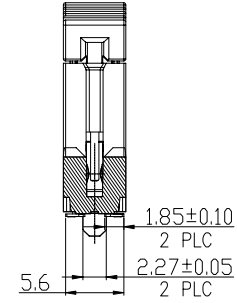
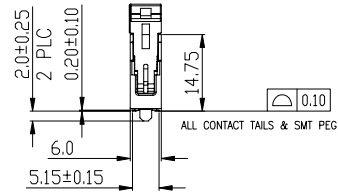
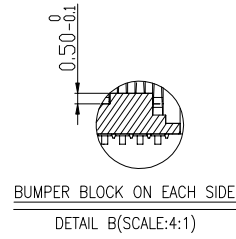
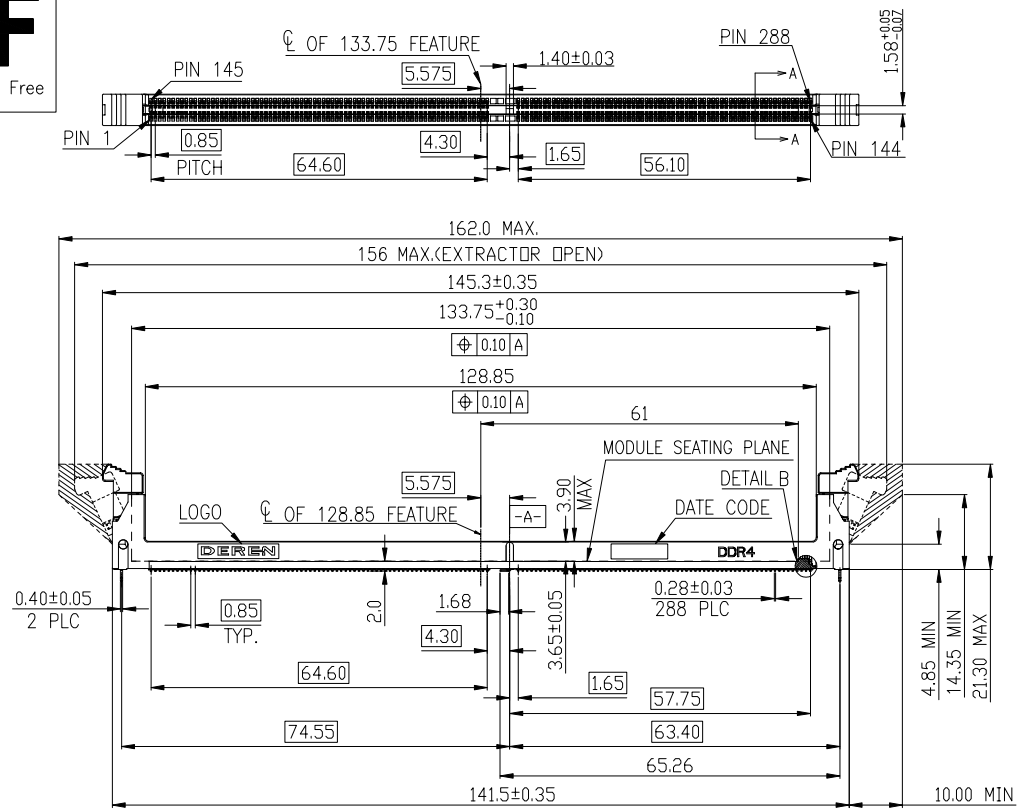

RECOMMENDED PCB LAYOUT(TOL:±0.05mm)

DIM	TOL	DIM	TOL
x.	±0.35	x.	±2'
.x	±0.25	.x	±1'
.xx	±0.20		
.xxx	±0.15		

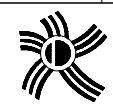

DRAW NO. SC2006456  
REV. A4

**DEREN**  
SHENZHEN DEREN ELECTRONIC CO., LTD

CUSTOMER DRAWING	DATE	TITLE: DDR4 288P BIG EAR MID PEG SMT TYPE NO CAP
DESIGN: Cay Zhao	05/15'20	P/N: SEE TABLE
CHECK: Bill Lin	05/15'20	SHEET: 1/3
APPROVAL: Smark Huo	05/15'20	SCALE: 1:1 UNIT: mm

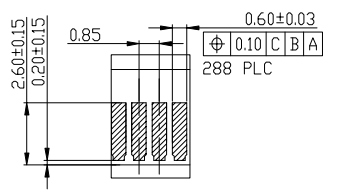
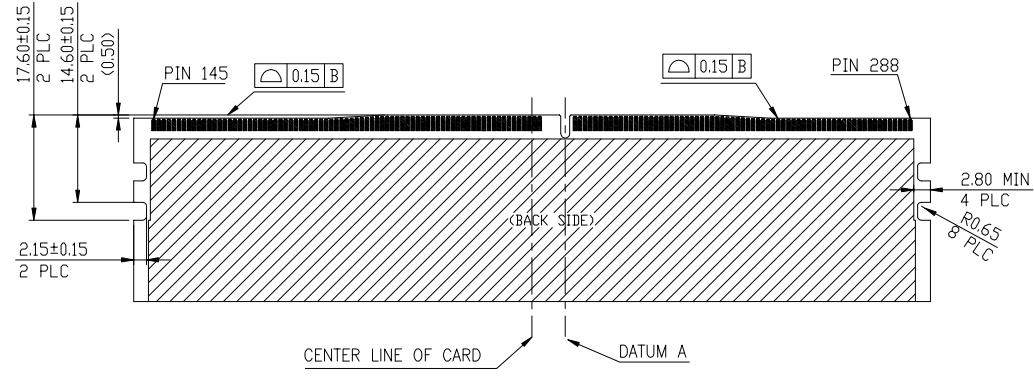
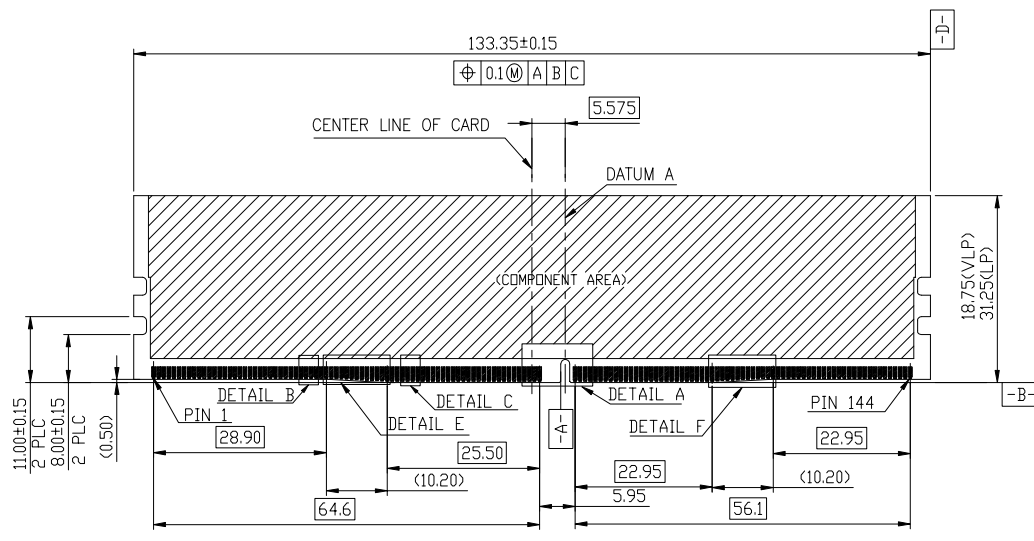

DETAIL C  
 SCALE 4:1

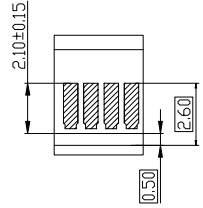

DETAIL B  
 SCALE 4:1

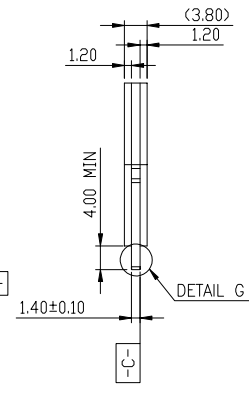

DETAIL G  
 SCALE 4:1

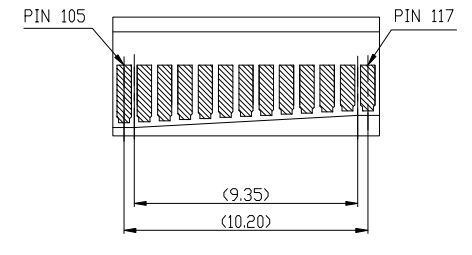

DETAIL F  
 SCALE 4:1

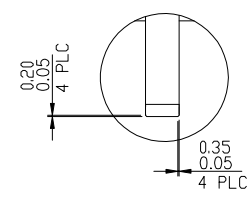

DETAIL G  
 SCALE 4:1

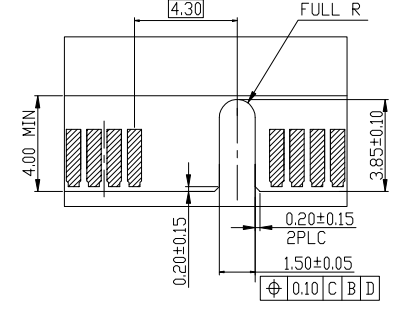

DETAIL A  
 SCALE 4:1

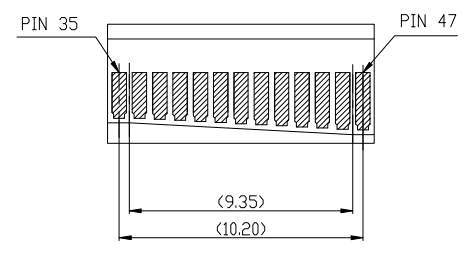

DETAIL E  
 SCALE 4:1

REV.	ECN NO.	LOCATION	DESCRIPTION	DATE	DESIGN
A1				2/14'20	Wanglie
A2				2/19'20	Wanglie
A3			Update P/N List	03/26'20	Cay Zhao
A4			Change packing tray	01/10'21	ZC.XE

DIM	TOL	DIM	TOL
.x	±0.35	.x	±2*
.x	±0.25	.x	±1*
.xx	±0.20		
.xxx	±0.15		



**DEREN**  
 SHENZHEN DEREN ELECTRONIC CO., LTD

DRAW NO.  
 SC2006456

CUSTOMER DRAWING  
 DESIGN: Cay Zhao 05/15'20  
 CHECK: Bill Lin 05/15'20  
 APPROVAL: Smark Huo 05/15'20

TITLE: DDR4 288P BIG EAR MID  
 PEG SMT TYPE NO CAP  
 P/N: SEE TABLE  
 SHEET: 2/3  
 SCALE: 1:1  
 UNIT: mm

REV.	ECN NO.	LOCATION	DESCRIPTION	DATE	DESIGN
A1				2/14'20	Wanglie
A2				2/19'20	Wanglie
A3			Update P/N List	03/26'20	Cay Zhao
A4			Change packing tray	01/10'21	ZC.XIE

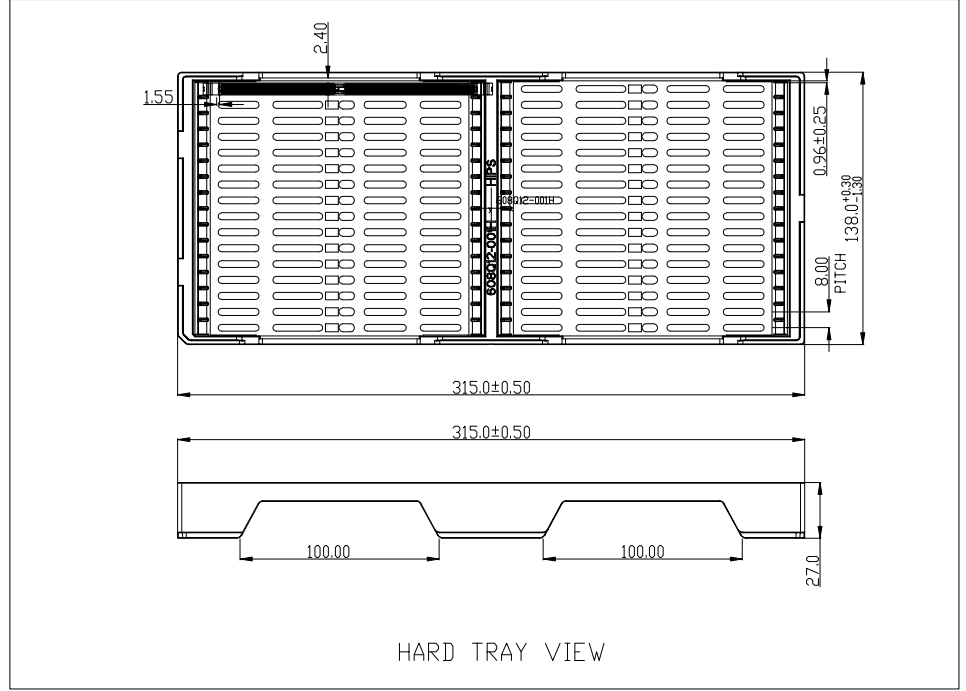
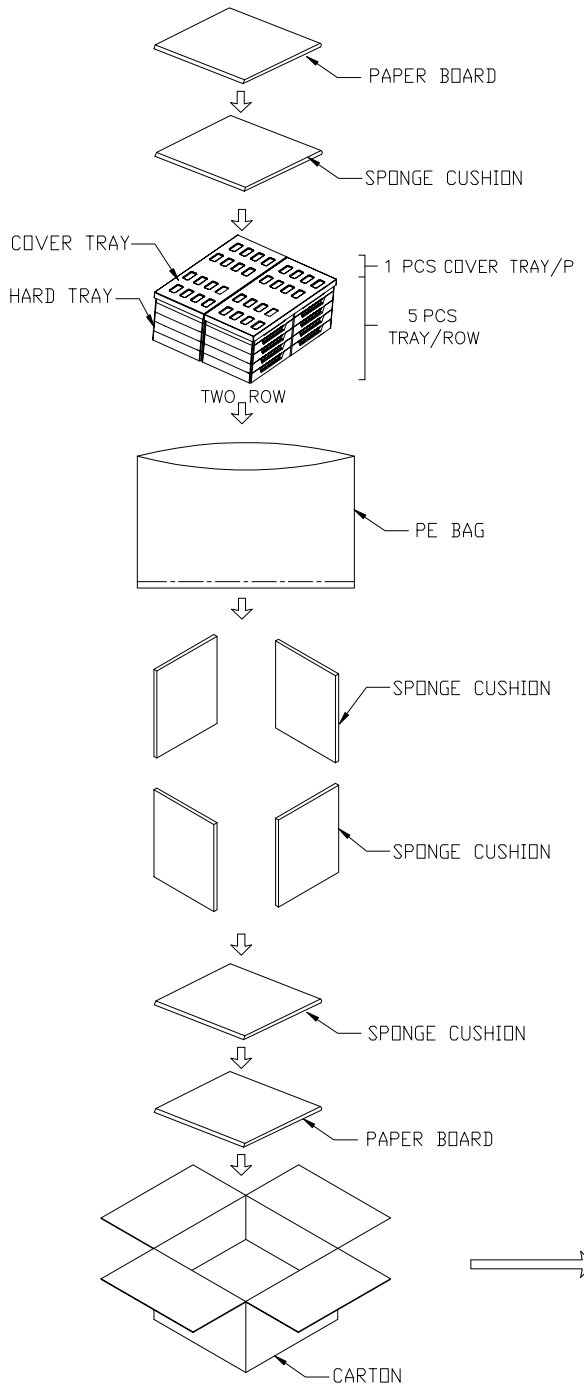

4.35kg	1.86kg	32	10	320
GROSS WEIGHT	NET WEIGHT	PCS/ TRAY	TRAY/ BOX	PCS/ BOX

DIM	TOL	DIM	TOL
.X	±1.00	.X	
.X	±0.50	.X	
.XX	±0.35		

**DEREN**  
SHENZHEN DEREN ELECTRONIC CO., LTD

CUSTOMER DRAWING	DATE	TITLE: DDR4 288P BIG EAR MID PEG SMT TYPE NO CAP
DESIGN: Cay Zhao	05/15'20	P/N: SEE TABLE
CHECK: Bill Lin	05/15'20	SHEET: 3/3
APPROVAL: Smark Huo	05/15'20	SCALE: 1:1 UNIT: mm

