

FORK LOCK TYPE :

TYPE 1

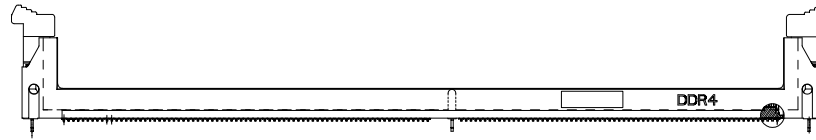

TYPE 2

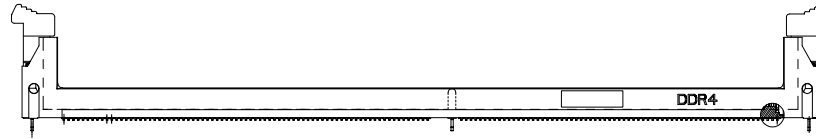

TYPE 3

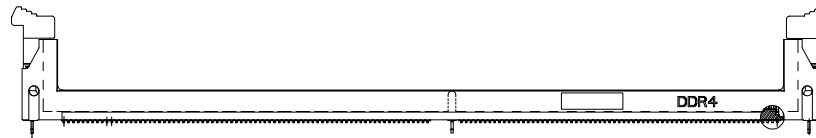

TYPE 4

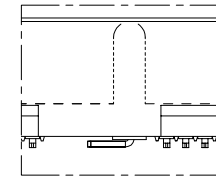
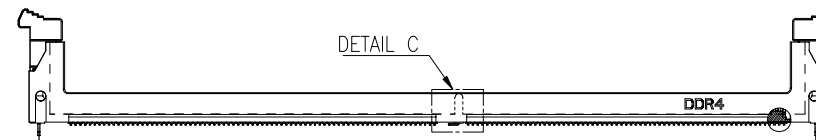

DETAIL C(SCALE:4:1)

REV.	ECN NO.	LOCATION	DESCRIPTION	DATE	DESIGN
A			UPDATE	5/10'21	ZC.XIE

DIM	TOL	DIM	TOL
.x	±0.35	.x	±2°
.x	±0.25	.x	±1°
.xx	±0.20		
.xxx	±0.15		



DEREN
SHENZHEN DEREN ELECTRONIC CO., LTD

DRAW NO.
SC2107184

REV. A

CUSTOMER DRAWING	DATE
DESIGN: Xie.ZC	5/10'21
CHECK: Bill Lin	5/10'21
APPROVAL: Smark Huo	5/10'21

TITLE: DDR4 288PIN SMT BIG EXTRACTOR SOLDER TAB		
P/N: SEE P/N INFORMATION		
SHEET: 2/5		
SCALE: 1:1	UNIT: mm	

HF
Halogen Free

REV.	ECN NO.	LOCATION	DESCRIPTION	DATE	DESIGN
A			UPDATE	5/10'21	ZC.XIE

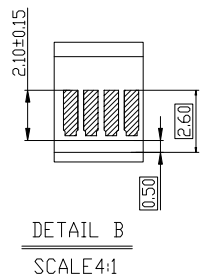
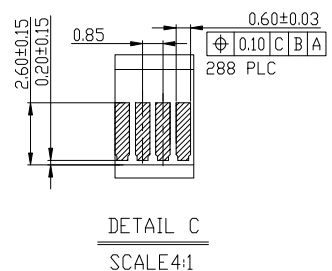
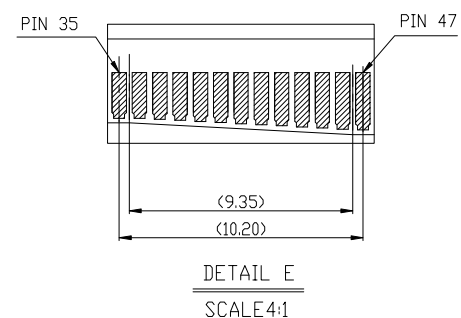
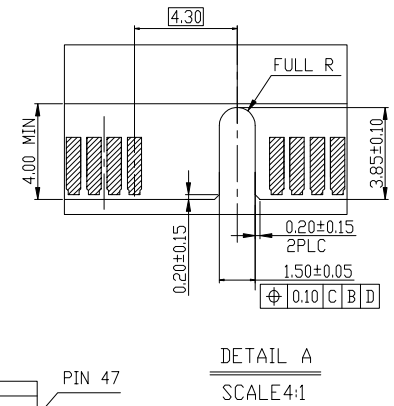
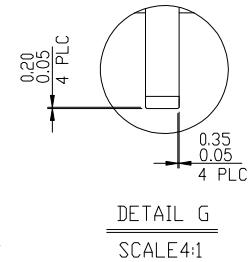
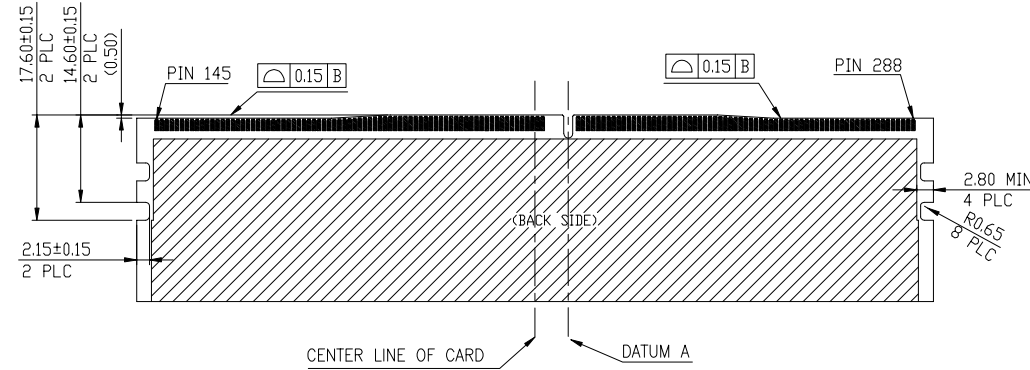
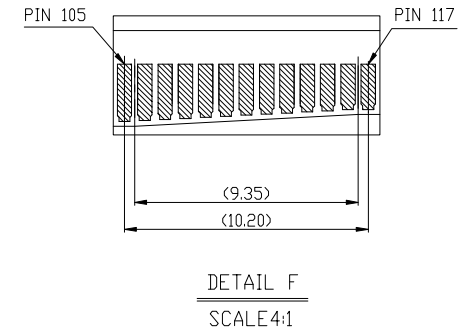
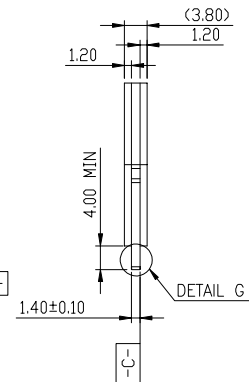
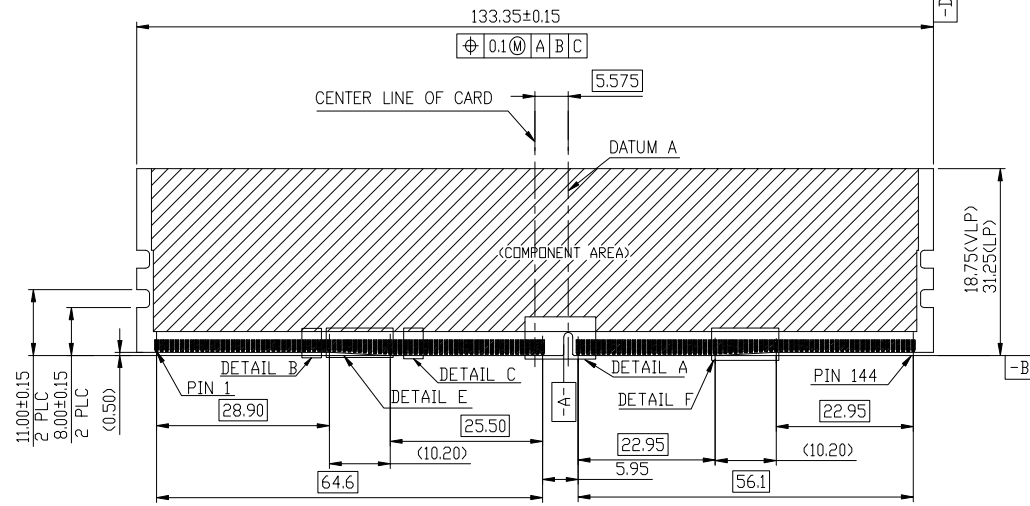

DIM	TOL	DIM	TOL
.x	±0.35	.x	±2*
.x	±0.25	.x	±1*
.xx	±0.20		
.xxx	±0.15		



DEREN
SHENZHEN DEREN ELECTRONIC CO., LTD

DRAW NO.
SC2107184
REV. A

CUSTOMER DRAWING
DESIGN: Xie.ZC
CHECK: Bill Lin
APPROVAL: Smark Huo
DATE: 5/10'21
5/10'21
5/10'21

TITLE: DDR4 288PIN SMT BIG EXTRACTOR SOLDER TAB
 P/N: SEE TABLE
 SHEET: 3/5
 SCALE: 1:1
 UNIT: mm

REV.	ECN NO.	LOCATION	DESCRIPTION	DATE	DESIGN
A			UPDATE	5/10'21	ZC.XIE

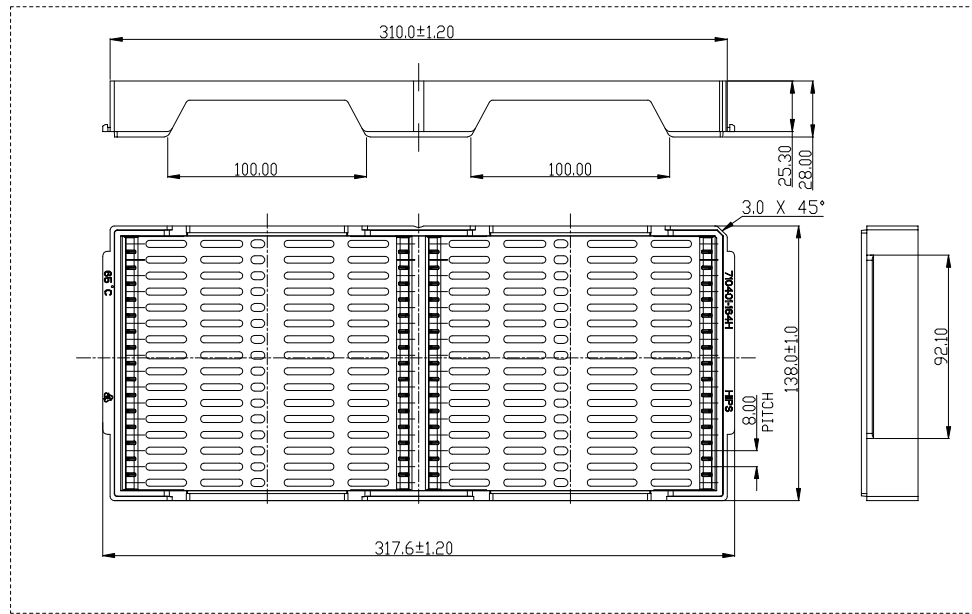
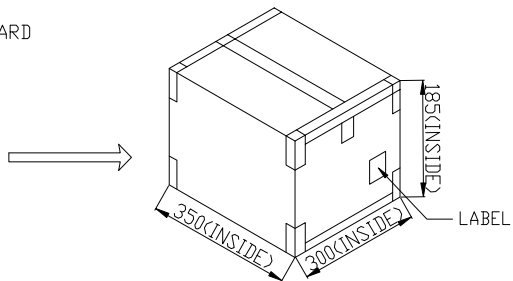
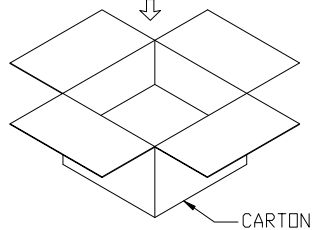
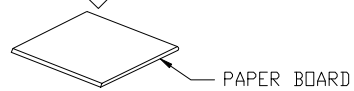
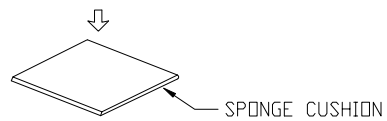
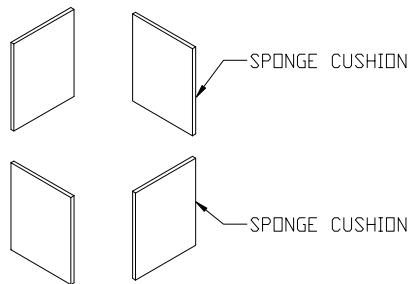
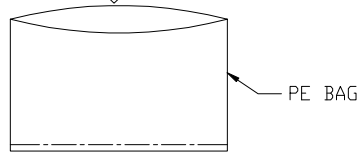
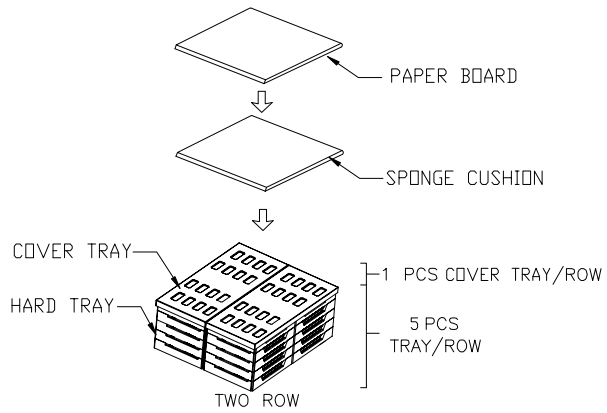

HARD TRAY VIEW

4.35kg	1.86kg	32	10	320
GROSS WEIGHT	NET WEIGHT	PCS/ TRAY	TRAY/ BOX	PCS/ BOX

DIM	TOL	DIM	TOL
X.	±1.00	X.	
.X	±0.50	.X	
.XX	±0.35		



DEREN
SHENZHEN DEREN ELECTRONIC CO., LTD

DRAW NO.
SC2107184

REV. A

CUSTOMER DRAWING	DESIGN:	DATE
	Xie.ZC	5/10'21
	Bill Lin	5/10'21
	Smak Huo	5/10'21

TITLE: DDR4 288PIN SMT BIG EXTRACTOR SOLDER TAB

P/N: SEE P/N INFORMATION

SHEET: 5/5	
SCALE: 1:1	UNIT: mm