

HF

Halogen Free

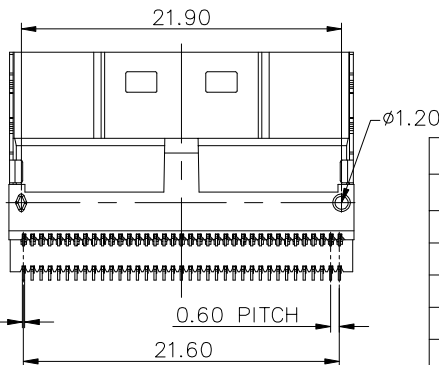
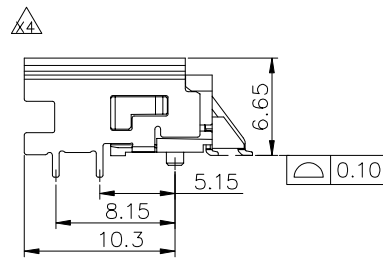
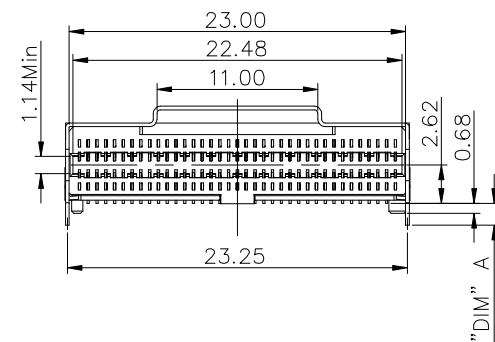
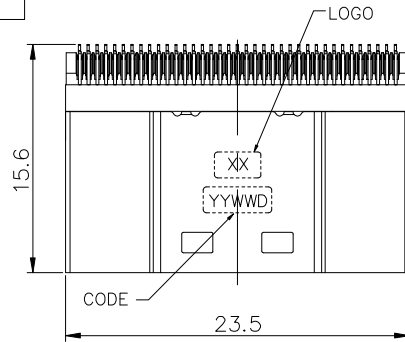

| DEREN P/N | "DIM"A | FINISH | LOGO |
|-------------|--------|------------|--------------|
| 562804-001H | 1.50mm | Au15u" | DR LOGO |
| 562804-002H | 1.50mm | Gold flash | |
| 562804-003H | 1.50mm | Au20u" | |
| 562804-004H | 1.50mm | Au30u" | |
| 562804-011H | 2.20mm | Au15u" | |
| 562804-012H | 3.00mm | Au15u" | WITHOUT LOGO |
| 562804-013H | 3.00mm | Au30u" | |
| 562804-015H | 2.20mm | Au30u" | |
| 562804-014H | 3.00mm | Au15u" | |

| REV. | ECN NO. | LOCATION | DESCRIPTION | DATE | DESIGN |
|------|---------|----------|----------------------|------|------------|
| X1 | | | INITIAL RELEASE | Mike | 2019.08.13 |
| X2 | | △2 | ADD NEW FOOT LENGTH | Mike | 2019.10.17 |
| X3 | | △3 | ADD NEW FOOT LENGTH | Mike | 2019.11.13 |
| X4 | | △4 | 裝板插口加殼, | Mike | 2020.01.02 |
| X5 | | △5 | ADD WITHOUT LOGO P/N | Mike | 2020.10.14 |

PRODUCT MEETS CONTROLLED SUBSTANCES SPEC. ROHS 2.0

NOTES:

- MATERIAL:
 - HOUSING/SPACER: HIGH TEMPERATURE PLASTIC. UL94V-0 COLOR:BLACK
 - CONTACT: COPPER ALLOY
 - SHELL: STAINLESS STEEL
- FINISH:
 - CONTACT;
 - GOLD PLATING(SEE P/N DESCRIPTION) ON CONTACT AREA.
 - G/F PLATING ON SOLDER TAIL AREA.
 - 50u"MIN. NICKEL UNDERPLATING OVERALL.
 - SHELL:
 - 50u" Min. NICKEL PLATING
- IR REFLOW CAPABLE TO 260°C MAX.
- PART NUMBER DESCRIPTION:

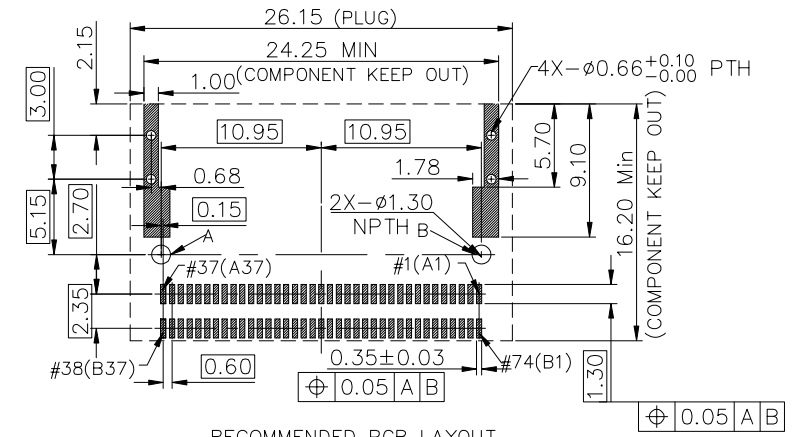

RECOMMENDED PCB LAYOUT
TOLERANCE ±0.05

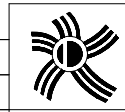

DEREN
SHENZHEN DEREN ELECTRONIC CO., LTD

| DIM | TOL | DIM | TOL | DRAW NO. SC1804656 | REV. X5 | CUSTOMER DRAWING | | DATE | | TITLE: SI in SAS X8 74pin rec R/A Type | | |
|-----|-------|-----|-----|-----------------------|----------|------------------|-----------|------------|------------------|--|------------|--|
| x. | ±0.30 | x. | ±2' | | | DESIGN: | Mikejiang | 2020.10.14 | P/N: 562804-0XXH | | SHEET: 1/2 | |
| .x | ±0.25 | .x | ±1' | | | CHECK: | BILL LIN | 2020.10.14 | SCALE: 1:1 | | UNIT: mm | |
| xx | ±0.15 | | | APPROVAL: | BILL LIN | 2020.10.14 | | | | | | |

HF

Halogen Free



← GATHER DIRECTION

FEEDING DIRECTION →

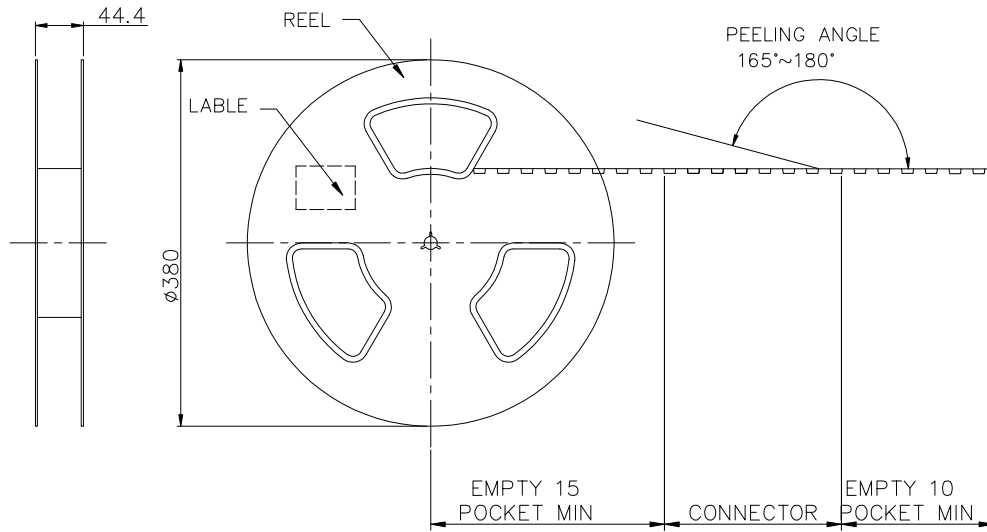

- MATERIAL:
COVER TAPE: PET, COLOR: CLEAR
CARRIER TAPE: PET
REEL: PET
SHIPPING BOX; CORRUGATED FIBER
- DIMENSION:
REEL: SEE DRAWING
BOX: 385X385X295mm
- QUANTITY: SEE TABLE

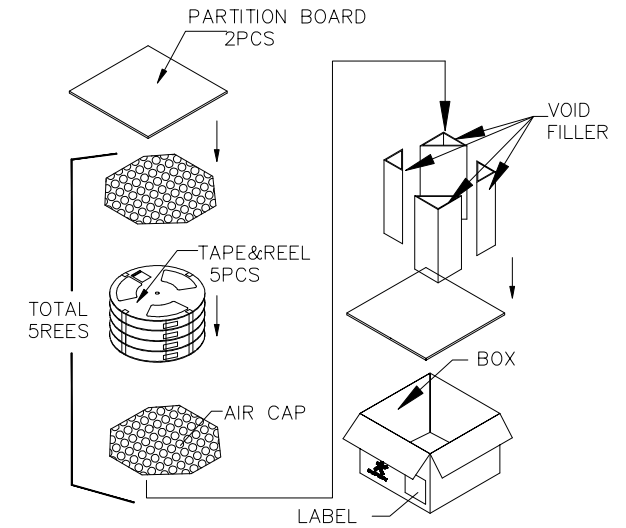
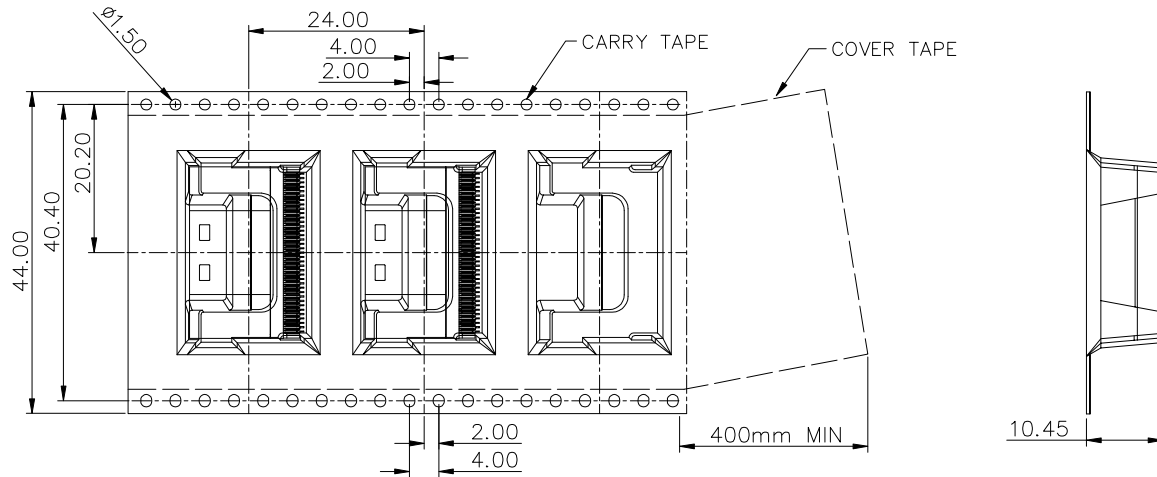

| | | | |
|----------|----------|---------|-------------|
| 350 | 5 | 1750 | 562804-0XXH |
| PCS/REEL | REEL/BOX | PCS/BOX | PART NUMBER |

| DIM | TOL | DIM | TOL |
|-----|-------|-----|-----|
| .x | ±0.30 | .x | ±2' |
| .x | ±0.20 | .x | ±1' |
| .xx | ±0.15 | | |

DEREN
SHENZHEN DEREN ELECTRONIC CO., LTD

| | | | | |
|------------------|-----------|--------------------|--|---------------------|
| CUSTOMER DRAWING | | DATE | TITLE: S1 im SAS X8 74pin rec R/A Type | |
| DESIGN: | Mikejiang | 2020.10.14 | P/N: 562804-0XXH | |
| CHECK: | BILL LIN | 2020.10.14 | SHEET: | 2/2 |
| REV. | X5 | APPROVAL: BILL LIN | 2020.10.14 | SCALE: 1:1 UNIT: mm |