

HF
Halogen Free

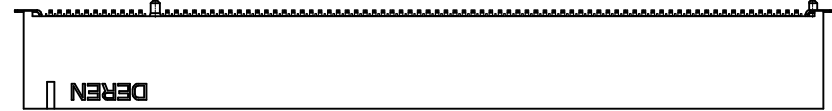

REV.	ECN NO.	LOCATION	DESCRIPTION	DATE	DESIGN
X1			INITIAL RELEASE	08/03'21	Chen
X2			CHANGE THE LENGTH OF MYLAR TO 50	05/13'22	Chen

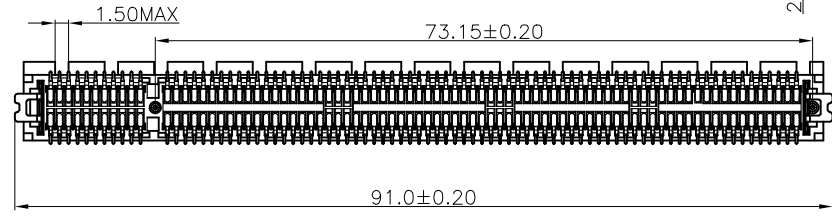
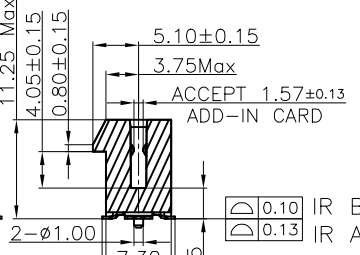
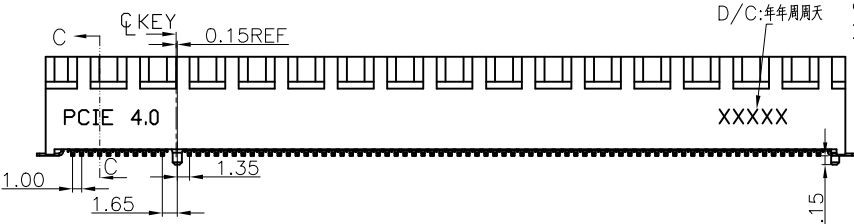
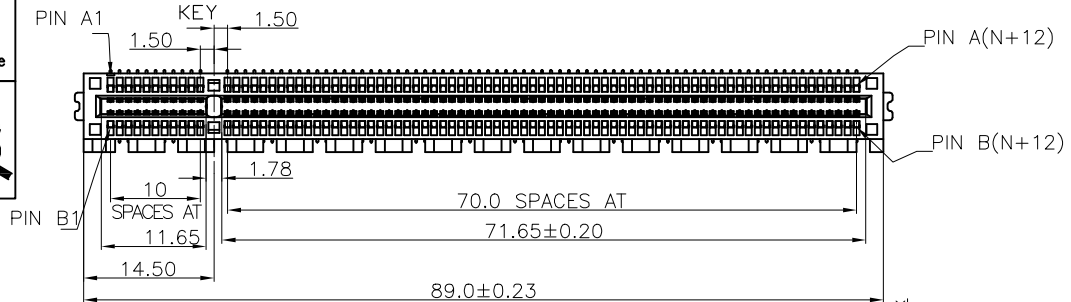

NOTES:
 PRODUCT MEETS CONTROLLED SUBSTANCES SPEC. ROHS 2.0
 1. MATERIAL:
 1.1 HOUSING:HIGH TEMPERATURE PLASTIC, UL94V-0;
 1.2 CONTACT:COPPER ALLOY
 1.3 PEG: STAINLESS STEEL
 2. FINISH:
 CONTACT:GOLD PLATING(SEE PART NUMBER) ON CONTACT AREA.
 2.54um[100u"] MIN. MATTE-TIN PLATING ON SOLDER TAIL AREA.
 1.27um[50u"] MIN. NICKEL UNDERPLATING OVERALL.
 PEG:2.54um[100u"] MIN. MATTE-TIN PLATING OVERALL.
 1.27um[50u"] MIN. NICKEL UNDERPLATING OVERALL.
 3.DATE CODE : YYWWD (YY: YEAR, WW: WEEK, D: DAY)
 4.USE 0.15mm STEEL MESH FOR WELDING PLATED.
 5.PART NUMBER DESCRIPTION:

564ZD4 - 0 1 2 H * 0 * *
 PACKING CODE:
 1:TRAY 4:TRAY&MYLAR
 2:REEL 5:HARD TRAY&MYLAR
 3:HARD TRAY
 HOUSING COLOR:1:BLACK 2:WITHE 3:BLUE
 4:BLACK&NO LOGO
 5:WITHE&NO LOGO
 6:BLUE&NO LOGO
 RESERVED
 RIDGE&POS CODE:
 7.164P&WITH RIDGE
 8.164P&WITHOUT RIDGE
 PLATING CODE: 1: G/F
 2: 15u" Min
 3: 30u" Min
 HALOGEN CODE: H: HALOGEN FREE

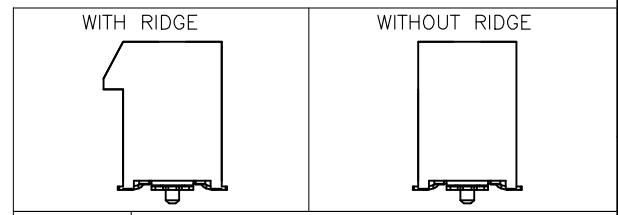

DEREN
 SHENZHEN DEREN ELECTRONIC CO., LTD

DIM	TOL	DIM	TOL
x.	±0.30	x.	±2'
.x	±0.25	.x	±1'
.xx	±0.20		

DRAW NO.	DESIGN:	Chen	DATE	05/13'22	TITLE:	PCI EXPRESS 4.0 SMT TYPE
SC200****	CHECK:	Bill.Lin	05/13'22	P/N:	SEE TABLE	
REV. X2	APPROVAL:	Smark.Huo	05/13'22	SHEET:	1/5	
				SCALE:	1:1	UNIT: mm

HF

Halogen Free

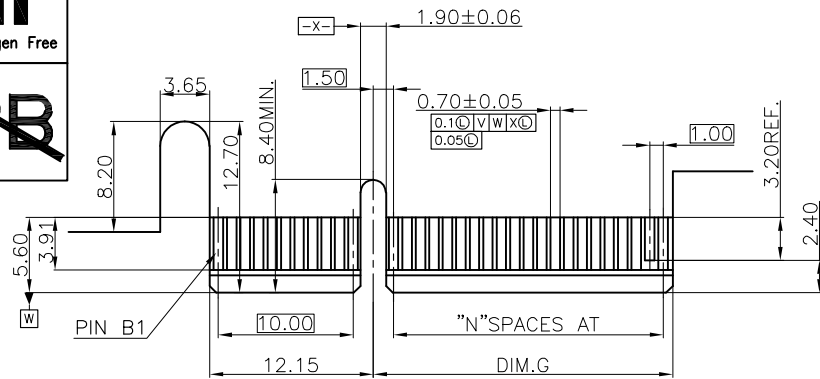

I/O PANEL DIRECTION
Recommended GOLD FINGER(B SIDE VIEW)

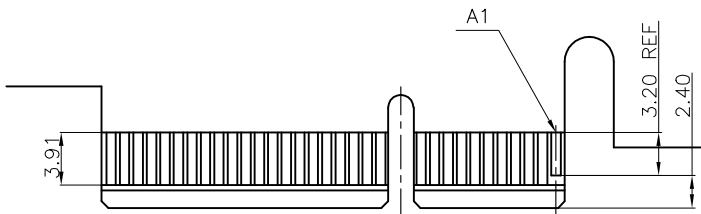

I/O PANEL DIRECTION
Recommended GOLD FINGER(A SIDE VIEW)

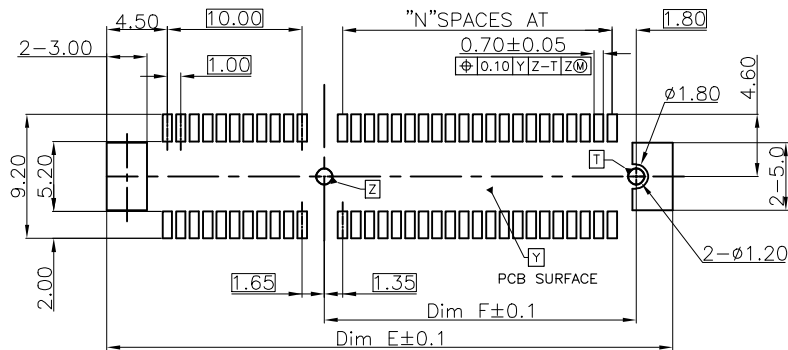

SOLDER PAD RECOMMEND P.C.B LAYOUT(COMPONENT SIDE)

DEFAULT TOLERANCES: ±0.05

ACROSS PADS

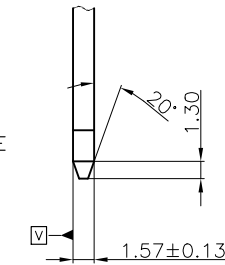

PIN "C"
SEE TABLE

NOTES:

NO TIE PERMITTED FROM CARD EDGE TO LEADING EDGE OF PAD FOR PINS A1 AND "C" CHAMFER EDGES MUST BE FREE OF CUTTING BURRS

1.ELECTRICAL CHARACTERISTICS:

- 1-1.CURRENT RATING: 1.1AMP.30°C RISE ABOVE AMBIENT.
- 1-2.CONTACT RESISTANCE: 30 MILLIOHMS MAX. INITIAL, 50 MILLIOHMS MAX. AFTER TEST.
- 1-3.INSULATION RESISTANCE: 1000 MEGOHMS MIN.
- 1-4.DIELECTRICAL WITHSTAND VOLTAGE: 500V AC MIN.AT SEA LEVEL.
- 1-5.CHARACTERISTIC IMPEDANCE: 85±10 OHMS

2.MECHANICAL CHARACTERISTICS:

- 2-1.INSERTION FORCE: 1.15N MAX.PER CONTACT PAIR.
- 2-2.REMOVAL FORCE: 0.15N MIN.PER CONTACT PAIR
- 2-3.DURABILITY: 50 MATING AND UNMATING CYCLES.
- 2-4.CONTACT RETENTION FORCE: 2N MIN.

3.ENVIRONMENTAL CHARACTERISTICS:

- 3-1.OPERATING TEMPERATURE RANGE:-40°C TO +105°C.

用REEL装须贴上MYLAR

贴MYLAR示意图

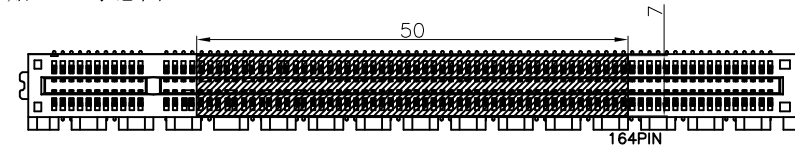

用TRAY装见料号是否贴上MYLAR

用HARD TRAY装见料号是否贴上MYLAR

#POS REF	N	DIM E	DIM F	DIM G	PIN C
164	70	92.00	73.15	72.15	B81

**DEREN**

SHENZHEN DEREN ELECTRONIC CO.,LTD

DIM	TOL	DIM	TOL	REV.	X2	APPROVAL:	DESIGN:	DATE:	TITLE:
.x	±0.30	.x	±2'			SC200****	Chen	05/13/22	PCI EXPRESS 4.0 SMT TYPE
.x	±0.25	.x	±1'				Biil.Lin	05/13/22	P/N: SEE TABLE
.xx	±0.20						Smark.Huo	05/13/22	SHEET: 2/5
									SCALE: 1:1 UNIT: mm

HF
Halogen Free

~~Pb~~

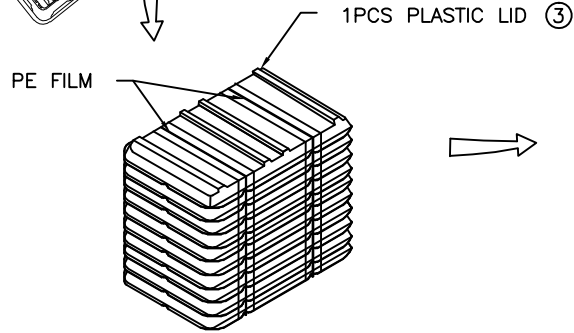
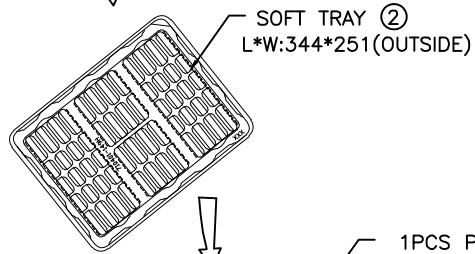
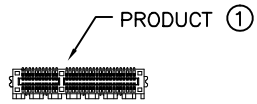

5	CARTON			1
4	BAG			1
3	LID			1
2	SOFT TRAY	-		20
1	CONN	-	-	SEE TABLE
NO.	PART NAME	PART NUMBER	SPEC.	QTY

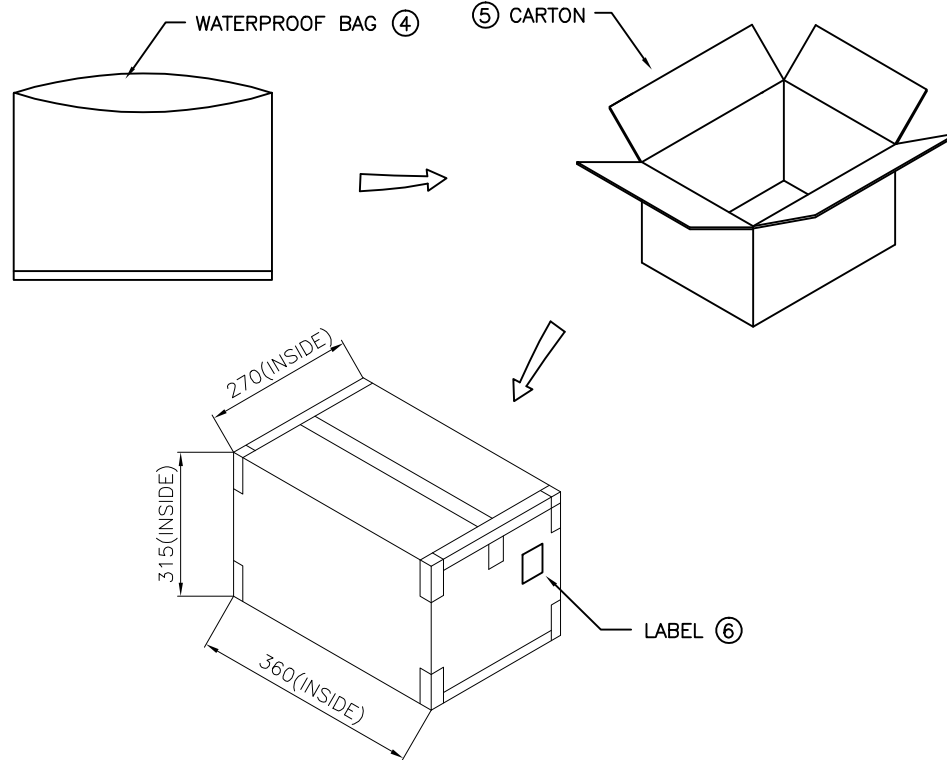

NOTE:

1. PUT THE PRODUCTS INTO TRAY WITH DIRECTION AS THE LEFT SKETCH SHOWN, Q'ty SEE TABLE, 12 TRAYS STACKED UP PER BUNDLE. THEN ADD AN EMPTY TRAY ON TOPSIDE.
2. WIND THE TWO ENDS WITH PE FILM.
3. PUT THE PRODUCTS BUNDLED INTO WATER-PROOF PE BAG, 1BUNDLES/BAG, THEN PUT INTO THE CARTON.
4. SEAL OUTER CARTON WITH PACKING TAPE LIKE A "H" SHAPE
5. PACKAGING QUANTITY:SEE TABLE.

P/N:	#POS REF	RIDGE	PCS/ROW OF TRAY	PCS/COLUMN OF TRAY	PCS/TRAY	TRAYS/CARTON	PCS/CARTON
564ZD4-012H*70*1	164	WITH	15	3	45	20	900
564ZD4-012H*80*1		WITHOUT	15	3	45	20	900

DIM	TOL	DIM	TOL
x.		x.	
.x		.x	
.xx			



DEREN
SHENZHEN DEREN ELECTRONIC CO., LTD

CUSTOMER DRAWING	DATE	TITLE: PCI EXPRESS 4.0 SMT TYPE
DESIGN: Chen	05/13'22	P/N: SEE TABLE
CHECK: Bill.Lin	05/13'22	SHEET: 3/5
REV. X2	APPROVAL: Smark.Huo	05/13'22
		SCALE: N/A UNIT: mm

HF
Halogen Free

~~Pb~~

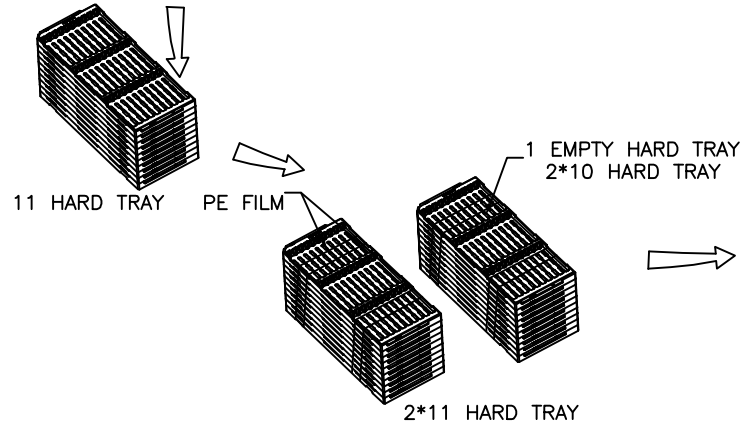
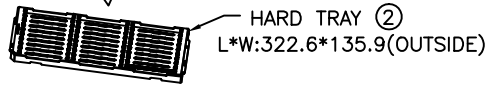
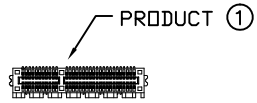

5	CARTON	-	350*300*215mm	1
4	BAG	-	520*600*0.15mm	1
3	DESICCANT	-	50g/BAG	2
2	HARD TRAY	-	322.6*135.9*16.84mm	22
1	CONN	-	-	SEE TABLE
NO.	PART NAME	PART NUMBER	SPEC.	QTY

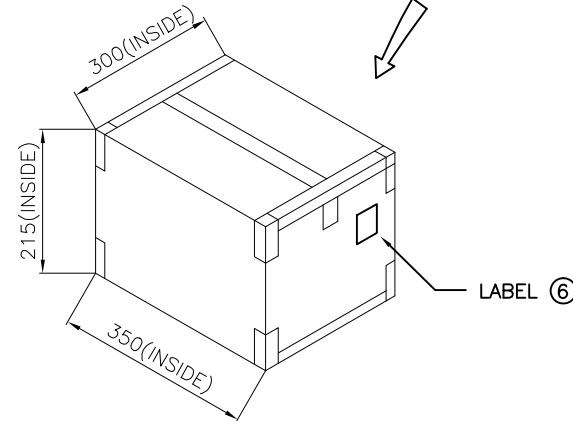
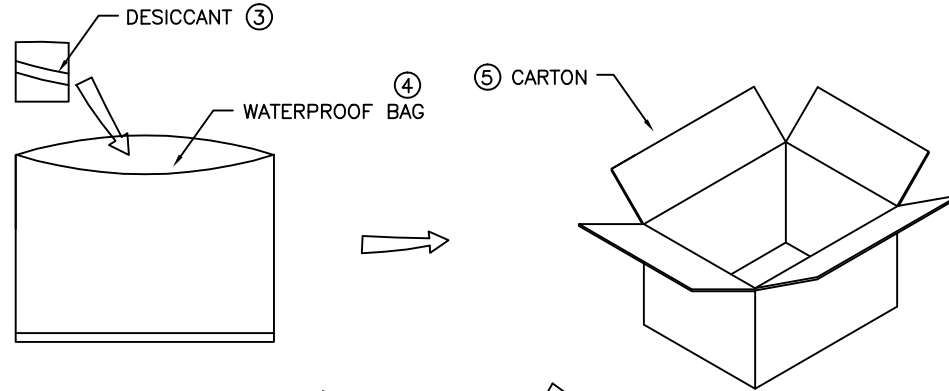

NOTE:

1. PUT THE PRODUCTS INTO HARD TRAY WITH DIRECTION AS THE LEFT SKETCH SHOWN, Q'TY SEE TABLE, 10 HARD TRAYS STACKED UP PER BUNDLE. THEN ADD AN EMPTY HARD TRAY ON TOPSIDE.
2. WIND THE TWO ENDS WITH PE FILM.
3. PUT THE PRODUCTS BUNDLED INTO WATER-PROOF PE BAG, 2 BUNDLES/BAG, THEN PUT INTO THE CARTON.
4. SEAL OUTER CARTON WITH PACKING TAPE LIKE A 'H' SHAPE
5. PACKAGING QUANTITY: SEE TABLE.

P/N:	#POS REF	RIDGE	PCS/ROW OF HARDTRAY	PCS/COLUMN OF HARD TRAY	PCS/HARD TRAY	HARD TRAY/CARTON	PCS/CARTON
564ZD4-012H*70*3	164	WITH	3	10	30	22	600
564ZD4-012H*80*3		WITHOUT	3	10	30	22	600

DIM	TOL	DIM	TOL
x.		x.	
.x		.x	
.xx			

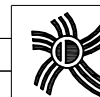

DEREN

SHENZHEN DEREN ELECTRONIC CO., LTD

DRAW NO. SC200****		DESIGN: Chen	DATE: 05/13'22	TITLE: PCI EXPRESS 4.0 SMT TYPE
REV. X2	APPROVAL: Smark.Huo	DATE: 05/13'22	P/N: SEE TABLE	SHEET: 4/5
			SCALE: N/A	UNIT: mm

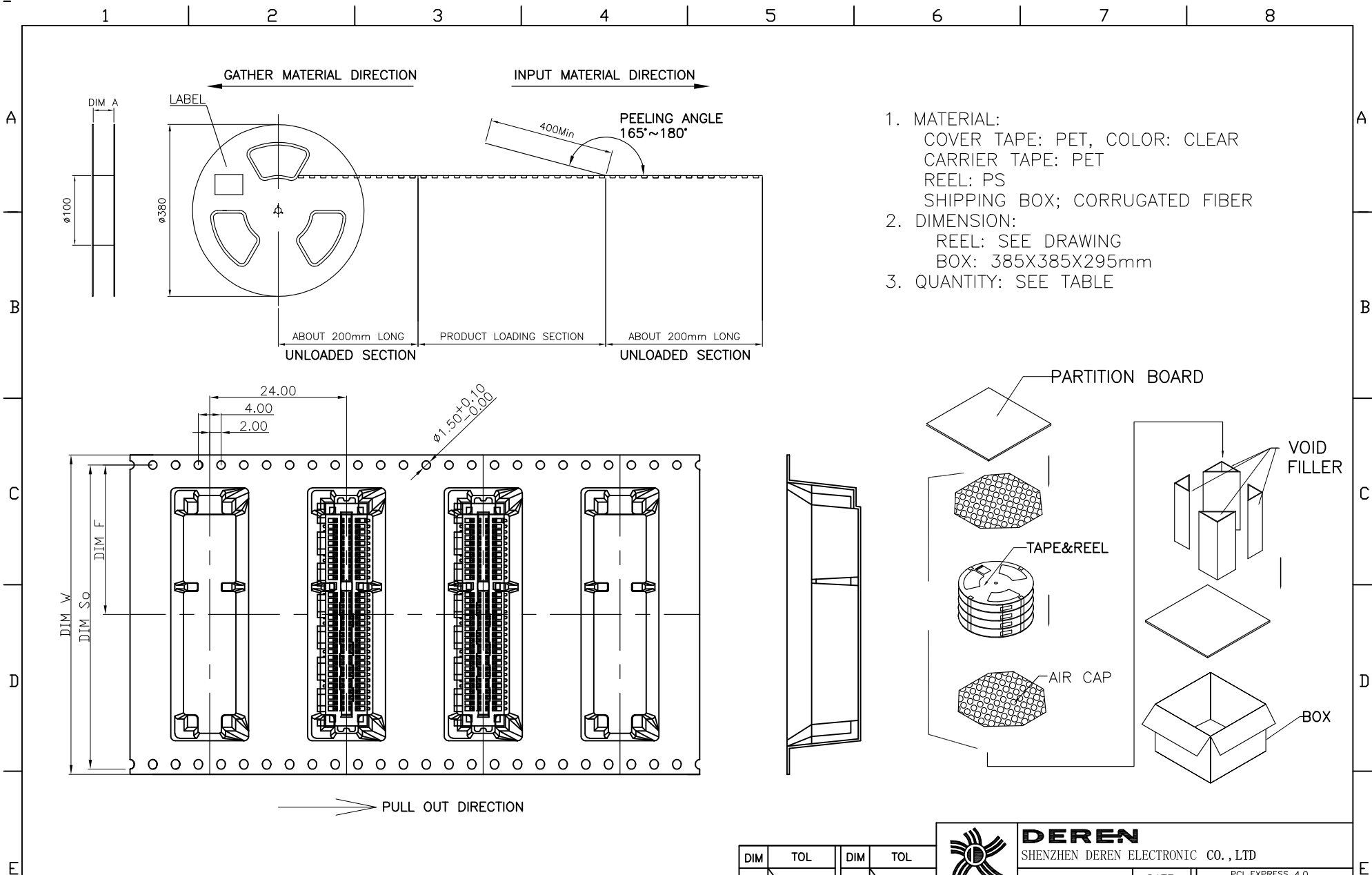

- MATERIAL:
COVER TAPE: PET, COLOR: CLEAR
CARRIER TAPE: PET
REEL: PS
SHIPPING BOX; CORRUGATED FIBER
- DIMENSION:
REEL: SEE DRAWING
BOX: 385X385X295mm
- QUANTITY: SEE TABLE

P/N:	#POS REF	RIDGE	DIM W	DIM So	DIM F	DIM A / REEL	PCS/ REEL	REELS/ CARTON	PCS/ CARTON
564ZD4-012H*70*2		WITH	104	100.4	50.2	104.4	300	2	600
564ZD4-012H*80*2	164	WITHOUT							

DIM	TOL	DIM	TOL	DEREN SHENZHEN DEREN ELECTRONIC CO., LTD	
x.		x.		CUSTOMER DRAWING	DATE
.x		.x		DESIGN: Chen	05/13'22
.xx		.xx		CHECK: Bill.Lin	05/13'22
				REV. X2	APPROVAL: Smark.Huo
					05/13'22

TITLE:	PCI EXPRESS 4.0 SMT TYPE	
P/N:	SEE TABLE	
SHEET:	5/5	
SCALE:	N/A	UNIT: mm