

HF
Halogen Free

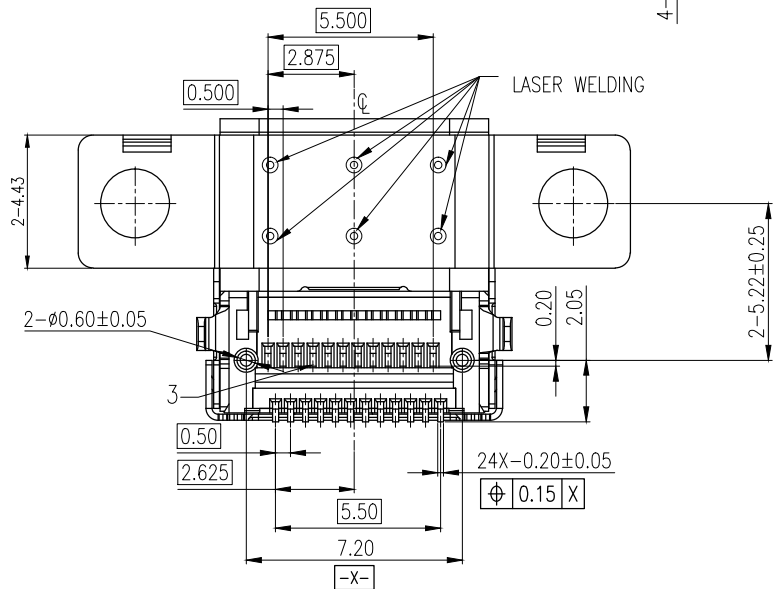

REV.	ECN NO.	LOCATION	DESCRIPTION	DATE	DESIGN
X1			INITIAL RELEASE	03/12'19	Alex

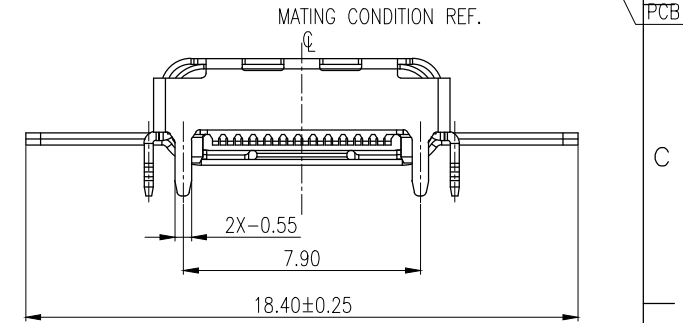
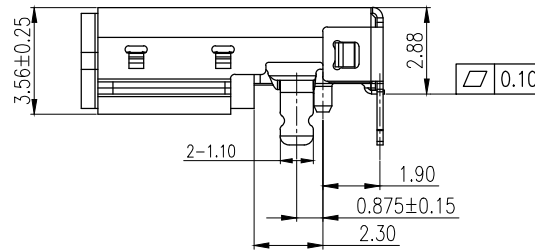
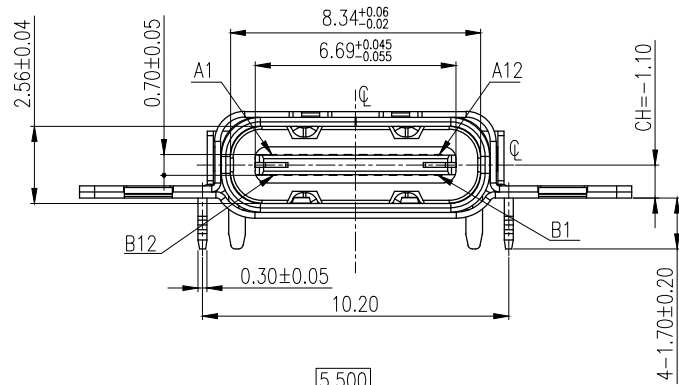
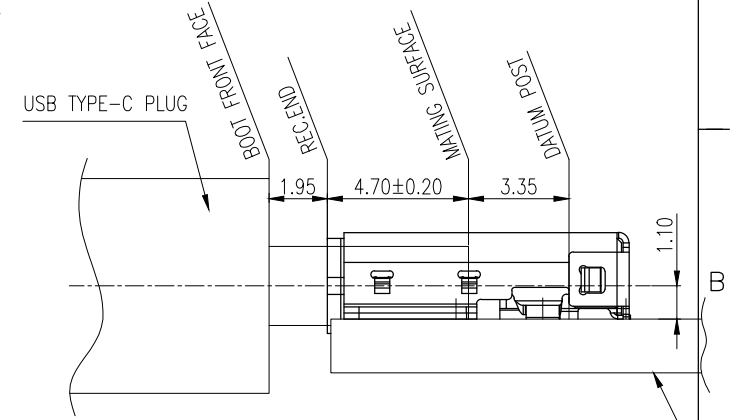
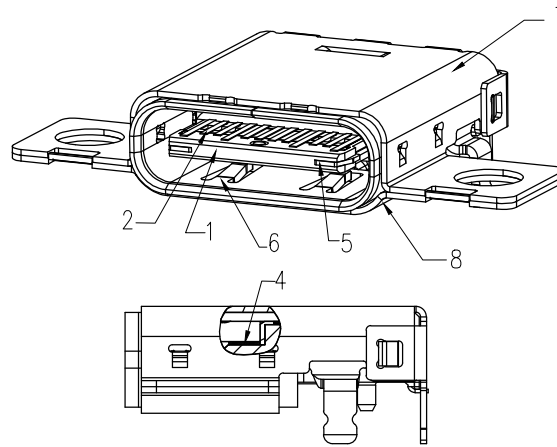
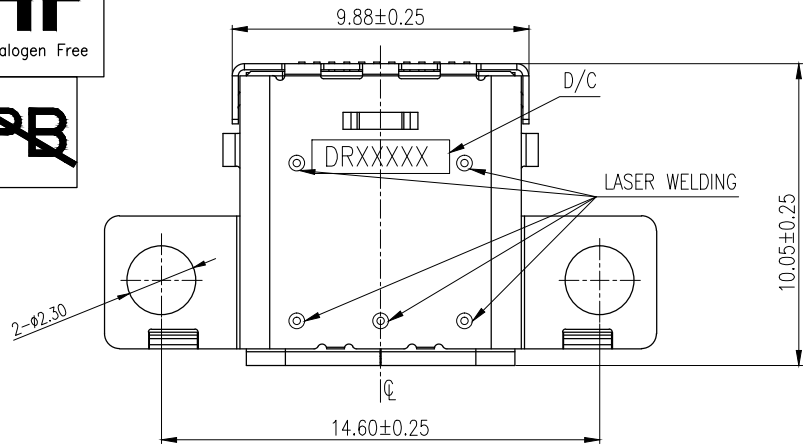

NO.	PART NAME	MATERIAL	FINISH	Q'TY
8	UNDER OUTER SHELL	STAINLESS STEEL	50u" Ni ALL OVER,COLOR:SEE PART NO.	1
7	UPPER OUTER SHELL	STAINLESS STEEL	50u" Ni ALL OVER,COLOR:SEE PART NO.	1
6	INNER SHELL	STAINLESS STEEL	50u" Ni ALL OVER,COLOR:SEE PART NO.	1
5	MID PLATE	STAINLESS STEEL	50U"NI ALL OVER	1
4	GND PLATE	STAINLESS STEEL	CLEAN	1
3	BOTTOM CONTACTS	COPPER ALLOY	50u"NI ALL OVER/Au SEE NOTES MATTE TIN 80u" IN SOLDER TAIL	12
2	TOP CONTACTS			12
1	HOUSING	LCP	BLACK, UL 94V-0	1

DIM	TOL	DIM	TOL
X.	±0.30	x.	±2'
.X	±0.25	.x	±1'
.XX	±0.15		
.XXX	±0.05		



DEREN

SHENZHEN DEREN ELECTRONIC CO., LTD

DRAW NO.
SC1XXXX

CUSTOMER DRAWING

DESIGN: Alex

CHECK:

APPROVAL: Charlie

DATE: 03/12'19

TITLE: USB TYPE C REC 24PIN
CL=1.1MM DUAL SMT CONN

P/N:40-42584-A2XXXXRH

SHEET: 1/3

SCALE: 1:1 UNIT: mm

HF
Halogen Free

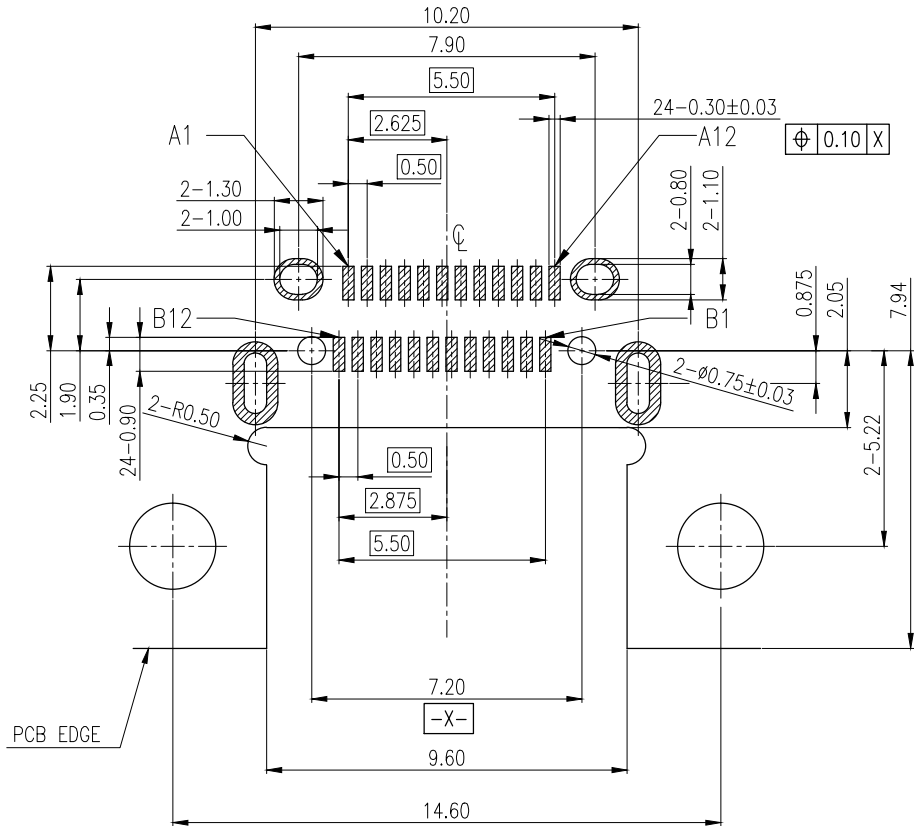

RECOMENED P.C.B LAYOUT
TOLERANCE: ±0.05

Pin	SIGNAL NAME	Pin	SIGNAL NAME
A1	GND	B12	GND
A2	SSTXp1	B11	SSRXp1
A3	SSTXn1	B10	SSRXn1
A4	VBUS	B9	VBUS
A5	CC1	B8	SBU2
A6	Dp1	B7	Dn2
A7	Dn1	B6	Dp2
A8	SBU1	B5	CC2
A9	VBUS	B4	VBUS
A10	SSRXn2	B3	SSTXn2
A11	SSRXp2	B2	SSTXp2
A12	GND	B1	GND

REV.	ECN NO.	LOCATION	DESCRIPTION	DATE	DESIGN
SEE PAGE 1/3					

NOTES:

- ELECTRICAL :
 - CONTACT CURRENT RATING :
5.0A FOR VBUS AND GND.
(i.e., Pins A4,A9,B4,B9)
1.25A FOR Vconn AND GND.
(i.e., Pins B5,A1,A12,B1,B12)
0.25A FOR ALL THE OTHERS CONTACTS.
 - INSULATION RESISTANCE :
100 MEGAOHMS MIN. AT 250VDC.
 - DIELECTRIC WITHSTANDING VOLTAGE :
100VAC MIN.
 - LOW LEVEL CONTACT RESISTANCE :
INITIAL 40mΩ MAX.
AFTER 50mΩ MAX.
- MECHANICAL CHARACTERISTICS :
 - INSERTION FORCE :5N~20N .
 - EXTRACTION FORCE :
8N~20N FROM 1 TO 1000 CYCLES.
6~20N FROM 1001 TO 10000 CYCLE.
 - DURABILITY :10,000 MATING CYCLES.
 - OPERATING TEMPERATURE :-55°C TO +85°C
- REFLOW SOLDER CAPABLE TO 260°C 10 SECONDS.
- PART NUMBER DESCRIPTION:
40-42584-A2XXXRHF

- HF:HALOGEN FREE
- PACKAGE CODE:
R:TAPE&REEL PACKING
- SHELL PLATING CODE: 0:BRIGHT Ni
1:BLACK Ni
- LOGO CODE:
0: W/ DEREN LOGO
1: W/O LOGO
- CONTACT PLATING CODE:
1: Au 30u"
2: Au 15u"
3: Gold Flash
- FORM CODE:
2:out shell with screw hole
- PIN NUMBER CODE: A: 24 PINS

DIM	TOL	DIM	TOL
X.	±0.30	x.	±2'
.X	±0.25	.x	±1'
.XX	±0.15		
.XXX	±0.05		

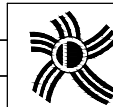

DEREN

SHENZHEN DEREN ELECTRONIC CO., LTD

CUSTOMER DRAWING		DATE		TITLE: USB TYPE C REC 24PIN CL=1.1MM DUAL SMT CONN	
DESIGN:	Alex	03/12'19		P/N:	40-42584-A2XXXRHF
CHECK:				SHEET:	2/3
APPROVAL:	Charlie	03/12'19		SCALE:	1:1
REV.	X1			UNIT:	mm

