

HF

Halogen Free

REV.	ECN NO.	LOCATION	DESCRIPTION	DATE	DESIGN
A			正版发行	12/01'21	Winner
B			依实际更新包装数量	01/05'22	Winner

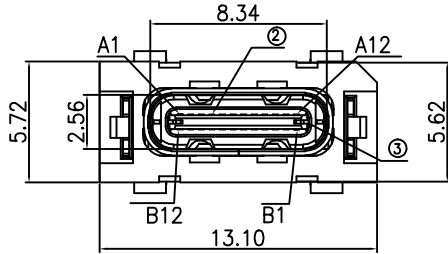

560Q27-00XH

H:HALOGEN FREE
CONTACT PLATING CODE:

- 1: Au 30u"
- 2: Gold Flash
- 3: Au 15u"

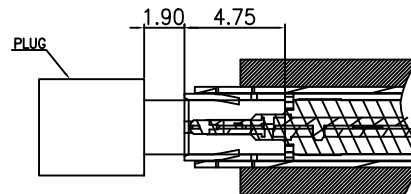
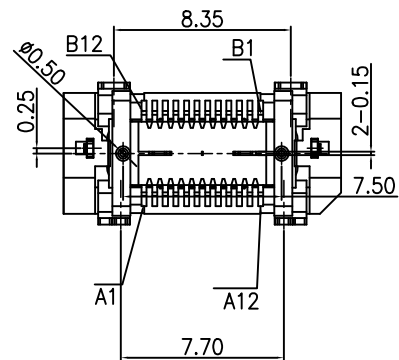
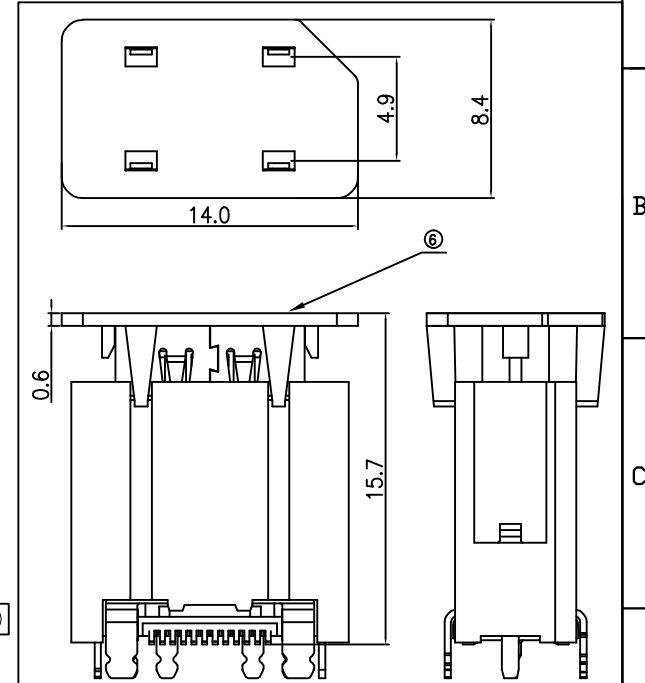
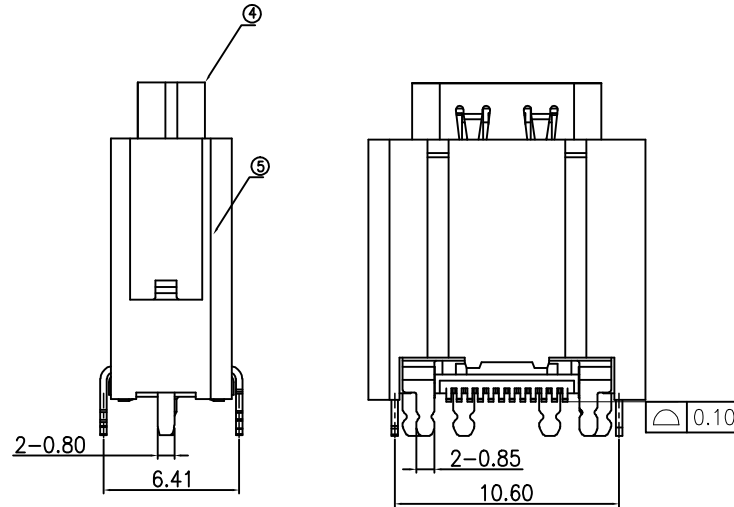
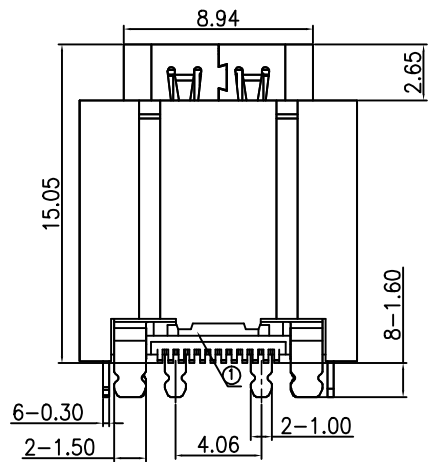

NO.	PART NAME	MATERIAL	FINISH	Q'TY
⑥	COVER	LCP	UL 94V-0,BLACK	1
⑤	MAIN HOUSING	LCP	UL 94V-0,BLACK	1
④	SHELL	STAINLESS STEEL	NI PLATED OVER ALL	1
③	MID PLATE	STAINLESS STEEL	NI PLATED OVER ALL	1
②	CONTACTS	COPPER ALLOY	Au PLATED ON CONTACT AREA AND 80u" MATTE Sn ON SOLDER TAIL	24
①	IM HOUSING	LCP	UL 94V-0,BLACK	1

DIM	TOL	DIM	TOL
x.	±0.30	x.	±2'
.x	±0.25	.x	±1'
.xx	±0.15		



DEREN
SHENZHEN DEREN ELECTRONIC CO., LTD

CUSTOMER DRAWING		DATE	TITLE: UC REC 24P VERTICAL H=15.05 SMT CONN.	
DRAW NO.	DESIGN:	Winner	01/05'22	P/N: 560Q27-00XH
SC2006653	CHECK:	Charles	01/05'22	SHEET: 1/3
REV. B	APPROVAL:	Smak	01/05'22	SCALE: 1:1 UNIT: mm

HF
Halogen Free

REV.	ECN NO.	LOCATION	DESCRIPTION	DATE	DESIGN
SEE SHEET 1					

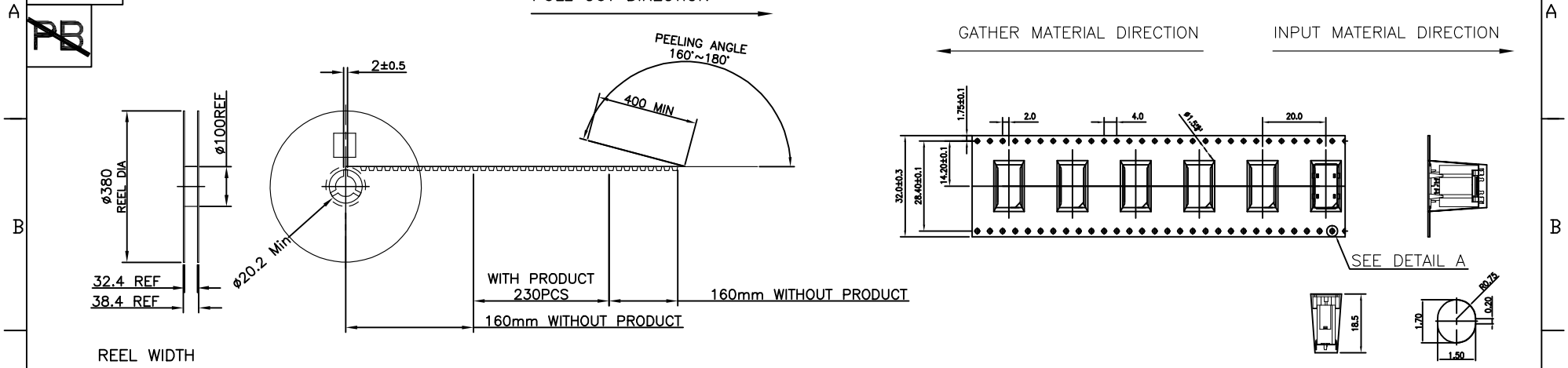

REEL WIDTH

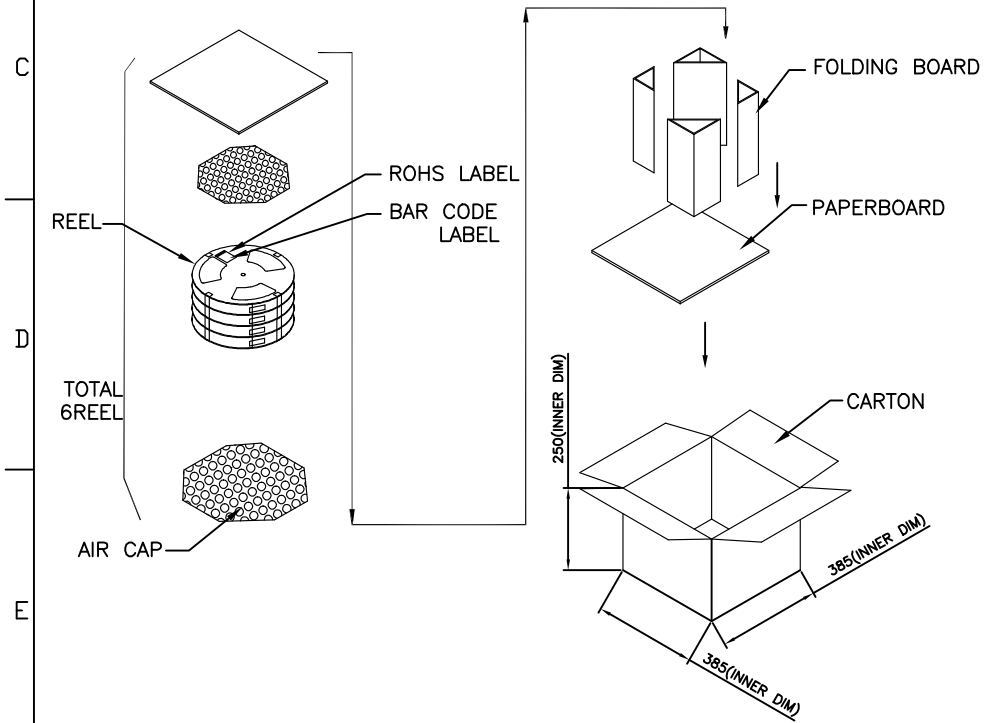

NOTES: (FOR REEL)
 PRODUCT MUST MEET CONTROLLED SUBSTANCES SPEC. ROHS 2.0
 PACKAGING MATERIAL IN PLASTIC, RUBBER, INK, PIGMENT AND PAINT
 MUST MEET CONTROLLED SUBSTANCES SPEC PER 230-702.
 * CADMIUM AND CADMIUM COMPOUNDS NOT TO EXCEED: 5 PPM.
 * LEAD, CADMIUM, CHROM VI AND MERCURY NOT TO EXCEED: 100 PPM (COMBINED).
 * CARRIER TAPES, COVER TAPES, REELS AND TAPED COMPONENTS MUST MEET THE
 REQUIREMENTS DEFINED PER EIA-481-B.

- MATERIAL:
 COVER TAPE: ANTISTATIC PS T=0.05±0.01mm, COLOR: CLEAR
 CARRIER TAPE: ANTISTATIC PET T=0.40±0.05mm, COLOR: CLEAR
 REEL: PS UL94V-0
 SHIPPING BOX: CORRUGATED FIBER
- DIMENSION:
 REEL: SEE DRAWING
 BOX: SEE DRAWING
- QUANTITY: SEE TABLE
- WEIGHT: SEE TABLE
- PEELING RESISTANCE: 10gf~130gf (for 12~56mm)
- PEELING SPEED: 300mm/MINUTES

230	6	1380	560Q27-00XH
PCS/ REEL	REEL/ BOX	PCS/ BOX	PART NUMBER

<table border="1"> <tr> <th>DIM</th> <th>TOL</th> <th>DIM</th> <th>TOL</th> </tr> <tr> <td>x.</td> <td>±0.50</td> <td>x.</td> <td>±2'</td> </tr> <tr> <td>.x</td> <td>±0.30</td> <td>.x</td> <td>±1'</td> </tr> <tr> <td>.xx</td> <td>±0.20</td> <td></td> <td></td> </tr> </table>	DIM	TOL	DIM	TOL	x.	±0.50	x.	±2'	.x	±0.30	.x	±1'	.xx	±0.20			<p>DEREN SHENZHEN DEREN ELECTRONIC CO., LTD</p>		CUSTOMER DRAWING		DATE	TITLE: UC REC 24P VERTICAL IH-15.05 SMT CONN.
	DIM	TOL	DIM	TOL																		
	x.	±0.50	x.	±2'																		
	.x	±0.30	.x	±1'																		
.xx	±0.20																					
DRAW NO. SC2006653		DESIGN: Winner	01/05'22	P/N: 560Q27-00XH																		
REV. B		CHECK: Charles	01/05'22	SHEET: 3/3																		
APPROVAL: Smark		01/05'22	SCALE: 1:1	UNIT: mm																		