

HF

Halogen Free



NOTES:

- PART NUMBER IS PARENT LINE ITEM NUMBER ON ENGINEERING BILL OF MATERIAL
- PARTS ARE TO BE CLEAN AND FREE FROM FOREIGN MATERIAL:DIRT,OIL,GREASE,OR ANY OTHER CONTAMINANTS.
- BREAK ALL SHARP CORNERS,EDGES,AND BURRS.
- ALL COMPONENTS SHOULD MEET INTEL'S ENVIRONMENTAL REQUIREMENTS.
- ALL DIMENSIONS AND MATERIALS CONTROLLED AT COMPONENT AND SUBASSEMBLY LEVELS.

REV.	ECN NO.	LOCATION	DESCRIPTION	DATE	DESIGN
A			INITIAL RELEASE	2022.02.25	Justin
B			MODIFY THE MARKING AND LEVER	2022.09.30	Justin
C			MODIFY THE MARKING AND SCREW	2023.06.18	Justin
D			修改颜色规格尺寸	2024.05.09	Justin

P/N	SPECIFICATION
56ZZC2-015H	THE COVER IS BLACK
56ZZC2-004H	THE COVER IS GRAY

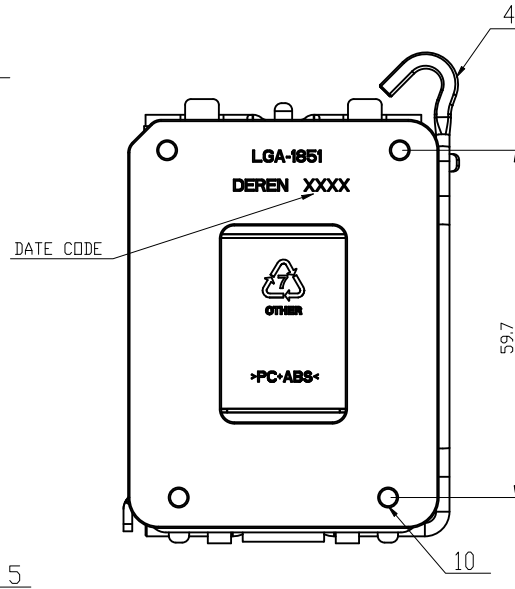
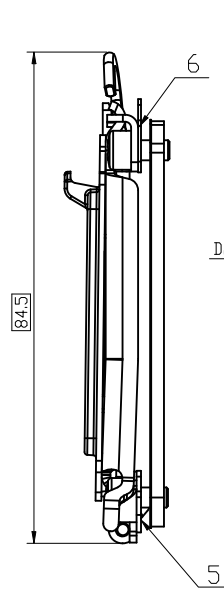
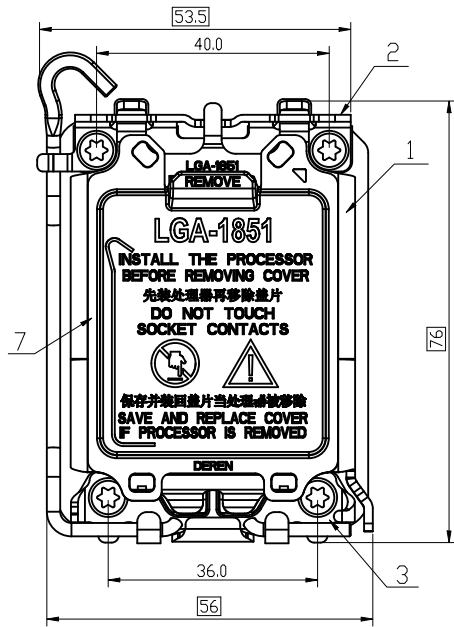

COMPONENT LIST		
ITEM	DESCRIPTION	Q'TY
1	LOAD PLATE	1
2	HING FRAME	1
3	LEVER FRAME	1
4	LEVER	1
5	LEVER FRAME INSULATOR	1
6	HING FRAME INSULATOR	1
7	LOAD PLATE INSULATOR	2
8	BACK PLATE	1
9	BACK PLATE INSULATOR	1
10	SCREW	4
11	DUST COVER	1

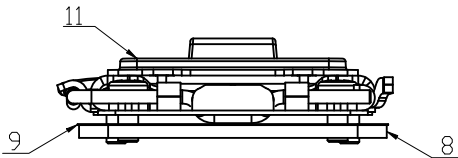

MOLD NUMBER			
DIM	TOL	DIM	TOL
.x	±0.50	.x	±0.1'
.X	±0.30	.X	±0.5'
.XX	±0.15	.XX	±0.1'



DEREN
SHENZHEN DEREN ELECTRONIC CO., LTD

C-DWG	-TY	DATE	TITLE:
SC2309112-13	Justin	2024.05.09	Socket V1 ILM ASM
DESIGN:	Kenneth	2024.05.09	P/N: 56ZZC2-XXXH
CHECK:	Andy	2024.05.09	SHEET: 1/5
APPROVAL:			SCALE: 1:1 UNIT: mm



HF
Halogen Free

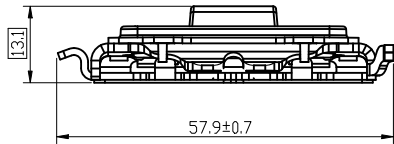
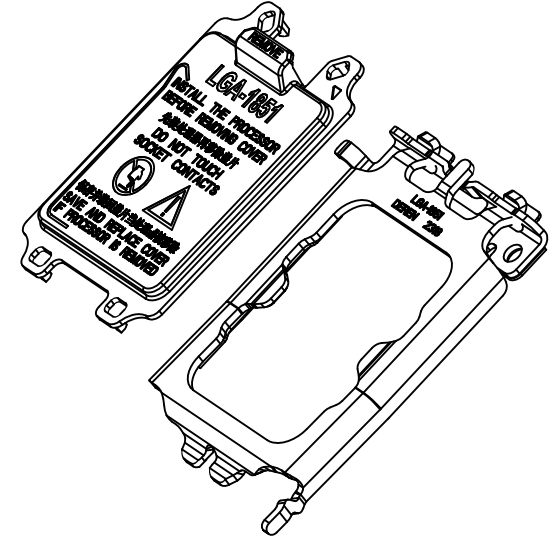
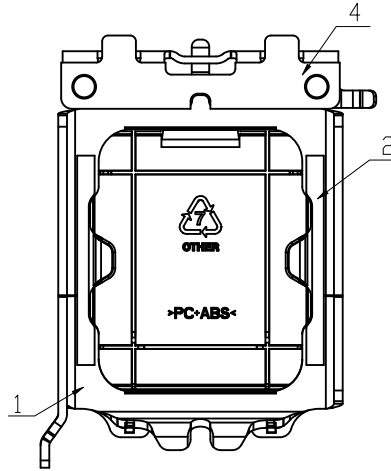
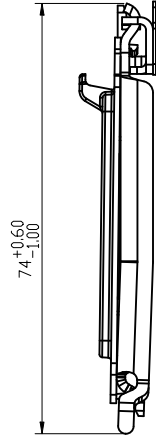
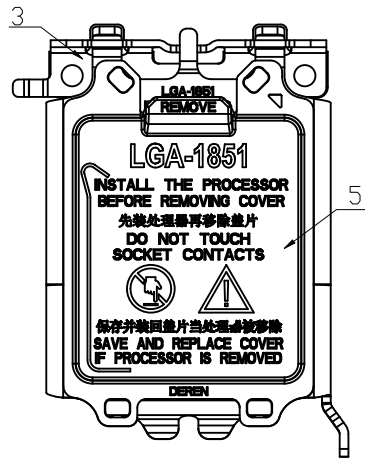

COMPONENT LIST		
ITEM	DESCRIPTION	Q'TY
1	LOAD PLATE	1
2	LOAD PLATE INSULATOR	2
3	HING FRAME	1
4	HING FRAME INSULATOR	1
5	DUST COVER	1

REV.	ECN NO.	LOCATION	DESCRIPTION	DATE	DESIGN
A			INITIAL RELEASE	2022.02.25	Justin
B			MODIFY THE MARKING AND LEVER	2022.09.30	Justin
C			MODIFY THE MARKING AND SCREW	2023.06.18	Justin
D			按端子颜色做绝缘胶套	2024.05.09	Justin



MOLD NUMBER					DEREN			SHENZHEN DEREN ELECTRONIC CO., LTD						
DIM	TOL	DIM	TOL		C-DWG	-TY	DATE	TITLE:	Socket V1 ILM ASM					
.X	±0.50	.X	±0.1'	DRAW NO.	DESIGN:	Justin	2024.05.09	P/N:	56ZZC2-XXXH					
.X	±0.30	.X	±0.5'						CHECK:	Kenneth	2024.05.09	SHEET:	2/5	
.XX	±0.15	.XX	±0.1'									REV.	D	APPROVAL:

HF

Halogen Free



REV.	ECN NO.	LOCATION	DESCRIPTION	DATE	DESIGN
A			INITIAL RELEASE	2022.02.25	Justin
B			MODIFY THE MARKING AND LEVER	2022.09.30	Justin
C			MODIFY THE MARKING AND SCREW	2023.06.18	Justin
D			修正顏色標識及尺寸	2024.05.09	Justin

COMPONENT LIST		
ITEM	DESCRIPTION	Q'TY
1	LEVER FRAME	1
2	LEVER FRAME INSULATOR	1
3	LEVER	1

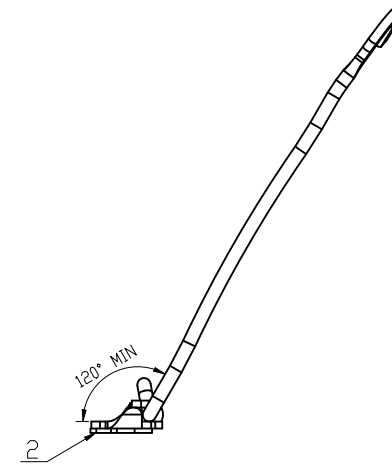
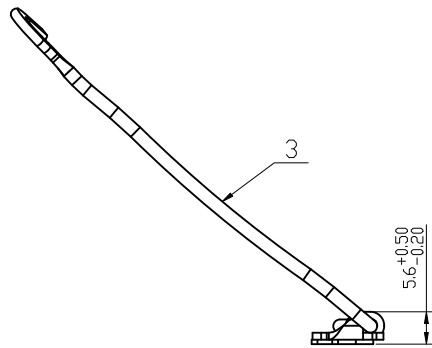
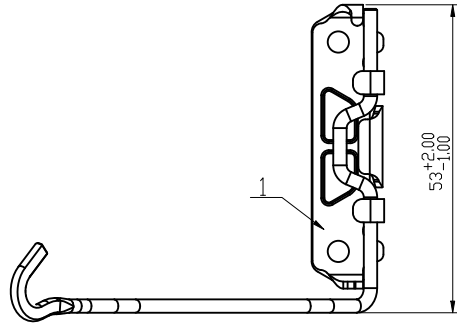

LEVER MAXIMUM OPEN CONDITION

MOLD NUMBER					DEREN			SHENZHEN DEREN ELECTRONIC CO., LTD		
DIM	TOL	DIM	TOL		C-DWG	-TY	DATE	TITLE: Socket V1 ILM ASM		
.x	±0.50	.x	±0.1'	DRAW NO. SC2309112-13	DESIGN:	Justin	2024.05.09	P/N: 56ZZC2-XXXH		
.X	±0.30	.X	±0.5'		CHECK:	Kenneth	2024.05.09	SHEET:	3/5	
.XX	±0.15	.XX	±0.1'		REV. D	APPROVAL:	Andy	2024.05.09	SCALE:	1:1

HF

Halogen Free



REV.	ECN NO.	LOCATION	DESCRIPTION	DATE	DESIGN
A			INITIAL RELEASE	2022.02.25	Justin
B			MODIFY THE MARKING AND LEVER	2022.09.30	Justin
C			MODIFY THE MARKING AND SCREW	2023.06.18	Justin
D			修正顏色標識及分	2024.05.09	Justin

COMPONENT LIST		
ITEM	DESCRIPTION	Q'TY
1	BACK PLATE	1
2	BACK PLATE INSULATOR	1

ATTACH ADHESIVE BACKED INSULATOR TO THE BACK PLATE

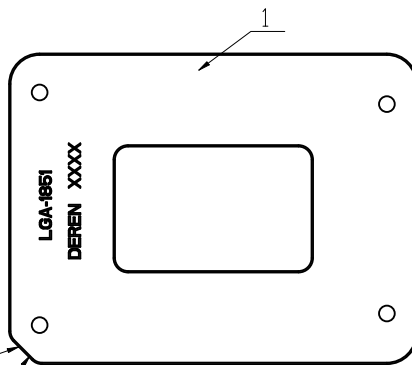
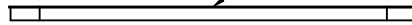

C4.65 (INSULATOR)

C4.50 (PLATE)

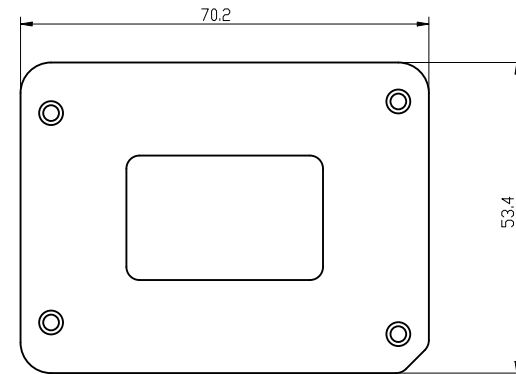
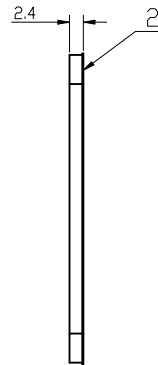

MOLD NUMBER					DEREN			SHENZHEN DEREN ELECTRONIC CO., LTD		
DIM	TOL	DIM	TOL		C-DWG	-TY	DATE	TITLE: Socket V1 ILM ASM		
x.	±0.50	x.	±0.1'	DRAW NO. SC2309112-13	DESIGN:	Justin	2024.05.09	P/N: 56ZZC2-XXXH		
.x	±0.30	.x	±0.5'		CHECK:	Kenneth	2024.05.09	SHEET:	4/5	
.xx	±0.15	.xx	±0.1'		REV.	D	APPROVAL:	Andy	2024.05.09	SCALE: 1:1 UNIT: mm

HF

Halogen Free



REV.	ECN NO.	LOCATION	DESCRIPTION	DATE	DESIGN
A			INITIAL RELEASE	2022.02.25	Justin
B			MODIFY THE MARKING AND LEVER	2022.09.30	Justin
C			MODIFY THE MARKING AND SCREW	2023.06.18	Justin
D			修正子顏色標識部分	2024.05.09	Justin

COMPONENT LIST		
ITEM	DESCRIPTION	Q'TY
1	SCREW	4

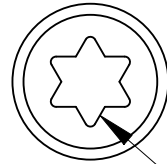

6 POINT T-20 TORX DRIVE
RECESS DEPTH 1.5MM

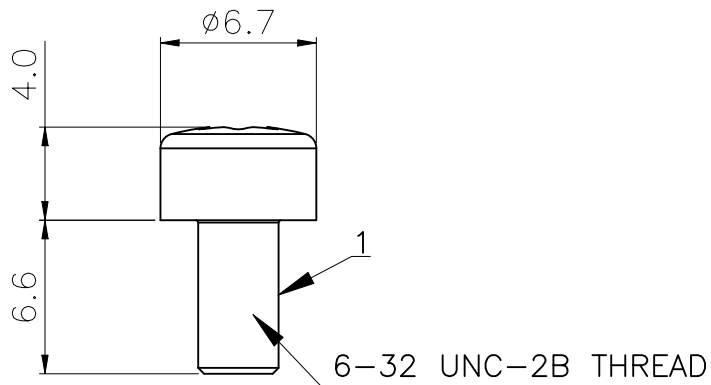

MOLD NUMBER					DEREN				
DIM	TOL	DIM	TOL		SHENZHEN DEREN ELECTRONIC CO., LTD				
x.	±0.50	x.	±0.1'	DRAW NO. SC2309112-13	C-DWG	-TY	DATE	TITLE: Socket V1 ILM ASM	
.x	±0.30	.x	±0.5'		DESIGN:	Justin	2024.05.09	P/N: 56ZZC2-XXXH	
.xx	±0.15	.xx	±0.1'	CHECK:	Kenneth	2024.05.09	SHEET:	5/5	
				REV.	D	APPROVAL:	Andy	2024.05.09	SCALE: 1:1 UNIT: mm