

# HF

Halogen Free

REV.	ECN NO.	LOCATION	DESCRIPTION	DATE	DESIGN
A			INITIAL RELEASE	12/09'22	HC

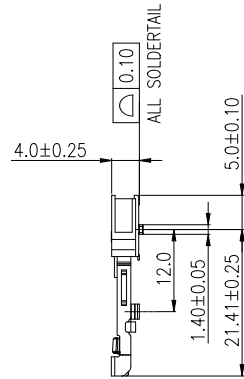
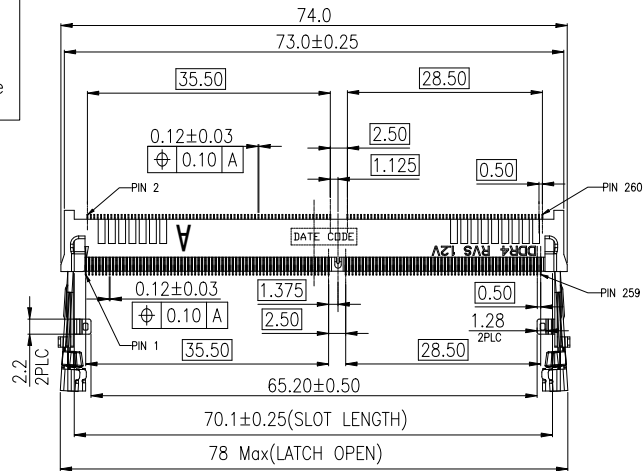

**NOTES:**

- MATERIAL:**
  - HOUSING:LCP,UL94V-0,COLOR:BLACK.
  - CONTACT:PHOSPHOR BRONZE.
  - LATCH:STAINLESS STEEL.
- FINISH:**
  - CONTACT:**
    - 50u" MIN NICKEL UNDERPLATED ALL OVER.
    - GOLD FLASH PLATING ON SOLDER TAIL.
    - GOLD PLATING (THICKNESS SEE P/N) ON CONTACT AREA.
  - SOLDER PEG:**
    - 50u" MIN NICKEL UNDERPLATED ALL OVER.
    - 100u" MIN MATTE TIN PLATING ENTIRE OVER.
- DATE CODE:YYWWDLX**

YY: YEAR (09: 2009)  
 WW: WEEK (25: THE 25TH WEEK)  
 D: DAY (1~7: SUNDAY~SATURDAY)  
 L: LINE NUMBER OF ASSEMBLY (A: LINE A)  
 X: MANUFACTURE CODE
- RECOMMENDED STENCIL THICKNESS:0.12mm Min.**
- UNSPECIFIED TOLERANCE:X.±0.5 .X±0.35 .XX±0.25 .XXX±0.15**
- PART NUMBER DESCRIPTION:**

567UD2-002H X R X X R

- PACKING CODE:
  - R:TAPE&REEL
- LOGO:
  - 0:NO LOGO
  - 1:DR LOGO
- COLOR:
  - 1:BLACK
  - 2:WHITE
- KEY TYPE:
  - R: RVS
- PLATING CODE:1: GF      2: Au5u"
  - 3: Au10u"    4:Au15u"
  - 5: Au30u"
- HALOGEN CODE:
  - H:HALOGEN FREE

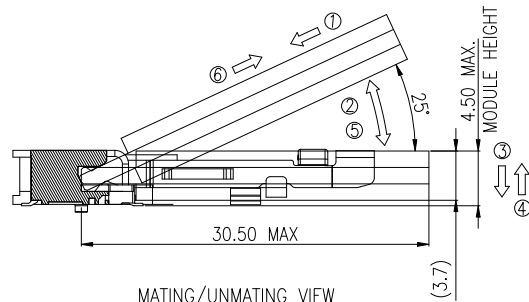
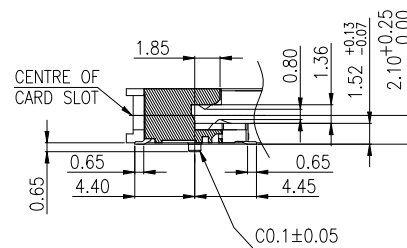
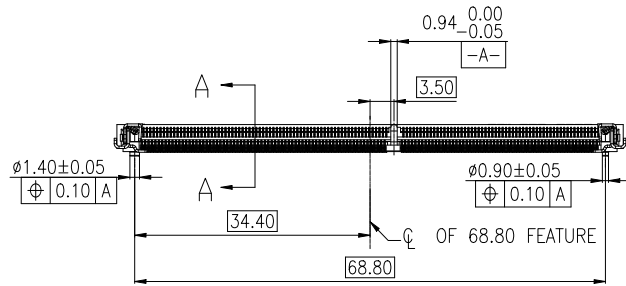

DIM	TOL	DIM	TOL	DEREN SHENZHEN DEREN ELECTRONIC CO.,LTD				
X.	±0.30	X.	±2'	DRAW NO. SC1905756-4	C-DWG:	TY	DATE	TITLE: DDR5 SO DIMM 4.0H RVS M/L GF ASSY
.X	±0.25	.X	±1'		DESIGN:	HC	12/09'22	P/N: SEE P/N
.XX	±0.20			CHECK:	ican.chen	12/09'22	SHEET: 1/3	⊕
				REV:	A	APPROVAL:	Bill.lin	12/09'22
							SCALE:	N/A
							UNIT:	mm

# HF

Halogen Free

REV.	ECN NO.	LOCATION	DESCRIPTION	DATE	DESIGN
A			INITIAL RELEASE	12/09'22	HC

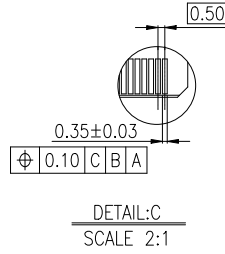
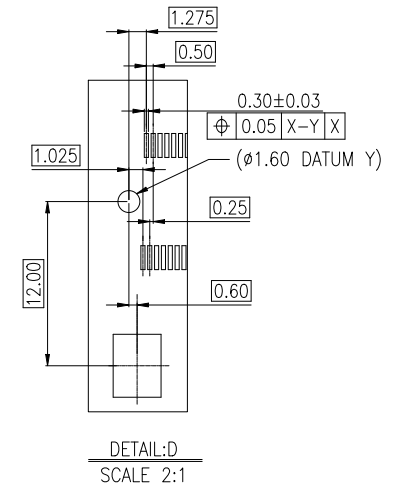
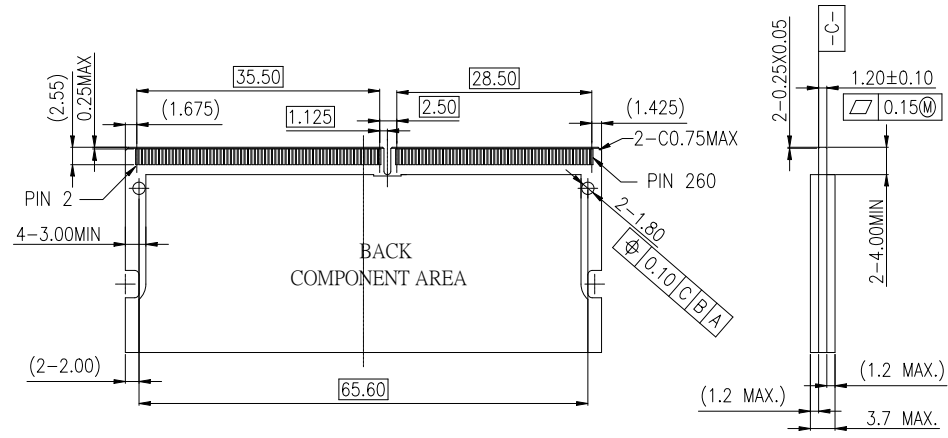
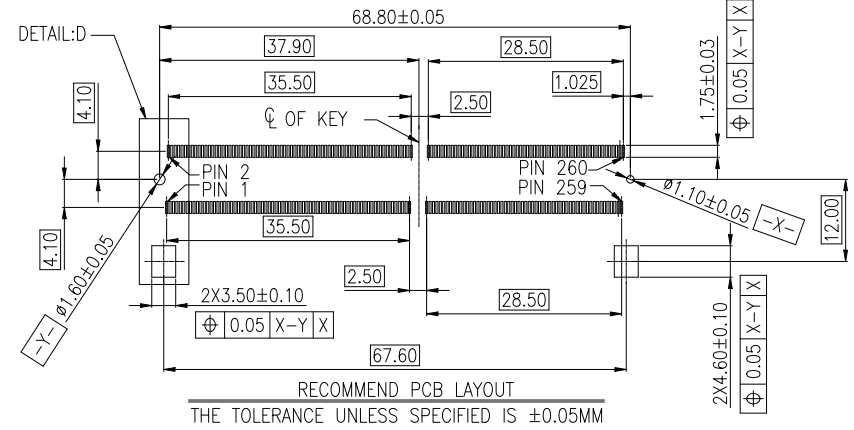
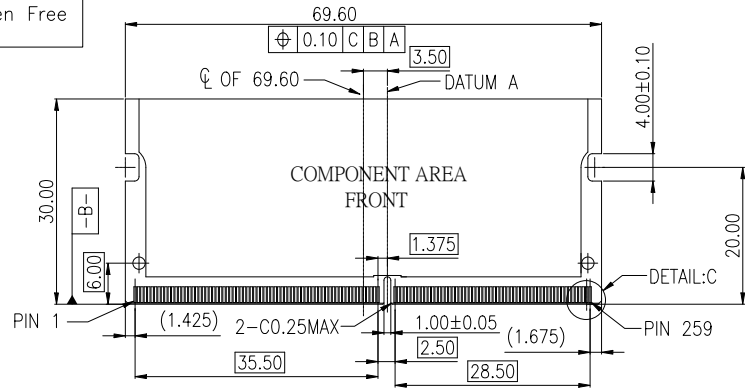

DIM	TOL	DIM	TOL	DEREN SHENZHEN DEREN ELECTRONIC CO., LTD				
X.	±0.30	X.	±2'	DRAW NO. SC1905756-4	C-DWG:	TY	DATE	TITLE: DDRIV SO DIMM 4.0H RVS M/L GF ASSY
.X	±0.25	.X	±1'		DESIGN:	HC	12/09'22	P/N:
.XX	±0.20			CHECK:	ican.chen	12/09'22	SHEET: 2/3	
				REV.	A	APPROVAL:	Bill.lin	12/09'22
							SCALE: N/A	UNIT: mm

