

**HF**  
Halogen Free

REV.	ECN NO.	LOCATION	DESCRIPTION	DATE	DESIGN
A			INITIAL RELEASE	2023.12.14	Sid Guo

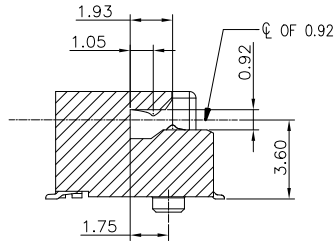

- NOTES:
- MATERIAL:
    - HOUSING:HIGH TEMPERATURE THERMOPLASTIC,UL94V-0,COLOR:BLACK
    - CONTACT:COPPER ALLOY.
    - SOLDER PEG:STAINLESS STEEL.
  - FINISH:
    - CONTACT: UNDERPLATING NICKEL 50u" MIN OVERALL, GF PLATING ON SOLDER AREA. CONTACT AREA: SEE NOTE 6.
    - SOLDER PEG: MATTE TIN 80u" MIN. AND NICKEL 50u" MIN UNDER PLATING.
  - DATE CODE: YYWDLX  
 YY: YEAR (09: 2009)  
 WW: WEEK (25: THE 25TH WEEK)  
 D: DAY (1~7: SUNDAY~SATURDAY)  
 L: LINE NUMBER OF ASSEMBLY  
 X: MANUFACTURE CODE
  - RECOMMENDED STENCIL THICKNESS:0.12MM
  - CONNECTOR ACTUAL PIN QUANTITY IS 67, AS THE KEY TAKING OUT 8 PINS.
  - PART NUMBER DESCRIPTION:  
 5621D3-001 H X B 1 0 2

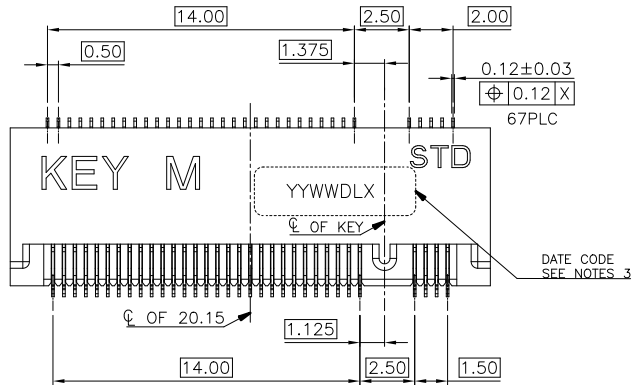
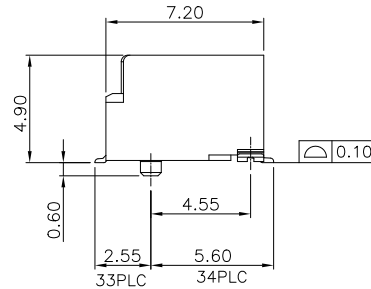
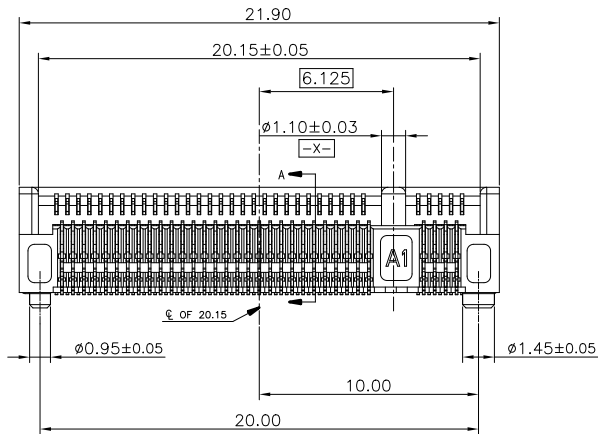

- PACKING CODE:  
 2: EMBOSS WIDTH 44mm, SLOT BACKWARD
- Logo:  
 0:No Logo  
 1:DR Logo
- Color:  
 1:Black  
 2:White
- KEY TYPE:  
 B: KEY M
- PLATING CODE:  
 1: AuGF      2: Au5u"  
 3: Au10u"    4: 15u"  
 5: Au30u"
- HALOGEN CODE:  
 H:HALOGEN FREE

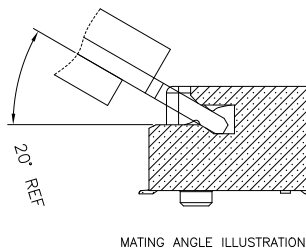
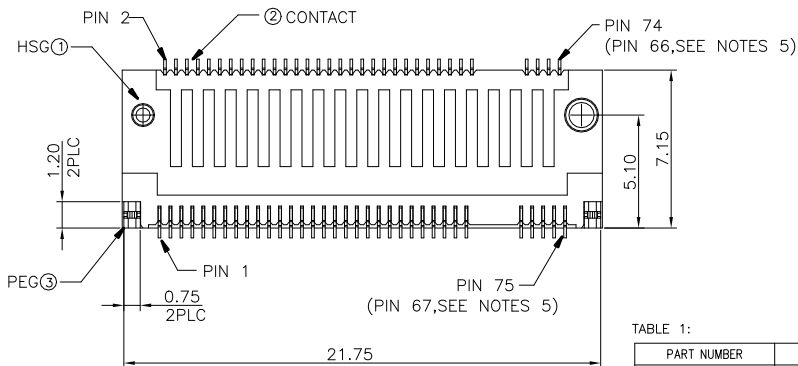
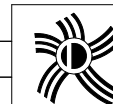

TABLE 1:

PART NUMBER	DESCRIPTION
5621D3-001H1B102	Au G/F ON CONTACT AREA
5621D3-001H2B102	Au 5u" ON CONTACT AREA
5621D3-001H3B102	Au 10u" ON CONTACT AREA
5621D3-001H4B102	Au 15u" ON CONTACT AREA
5621D3-001H5B102	Au 30u" ON CONTACT AREA

DIM	TOL	DIM	TOL
x.	±0.30	x.	±2°
.x	±0.25	.x	±1°
.xx	±0.15		



**DEREN**  
SHENZHEN DEREN ELECTRONIC CO., LTD

DRAW NO. SC2006910-4	C-DWG:	TY	DATE	TITLE: NGFF 4.80H KEY M STD NO Logo
	DESIGN:	Sid Guo	2023.12.14	P/N: SEE TABLE 1
REV. A	CHECK:	Mike.Chen	2023.12.14	SHEET: 1/3
	APPROVAL:	Bill Lin	2023.12.14	SCALE: N/A UNIT: mm

# HF

Halogen Free

## PLUG PCB

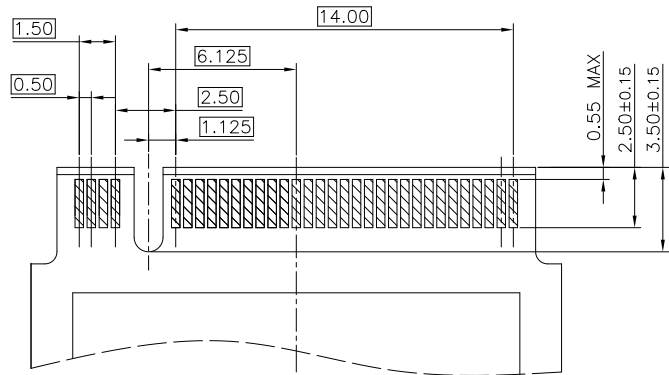

BOTTOM SIDE

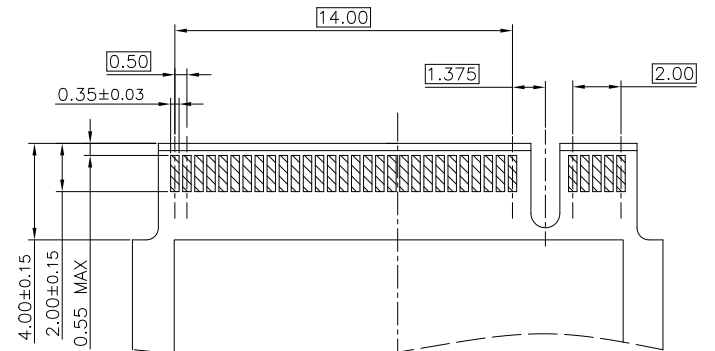
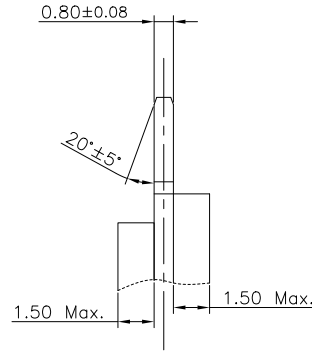

TOP SIDE

## RECOMMENDED PCB LAYOUT(TOP VIEW)

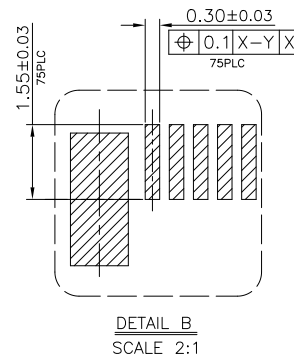
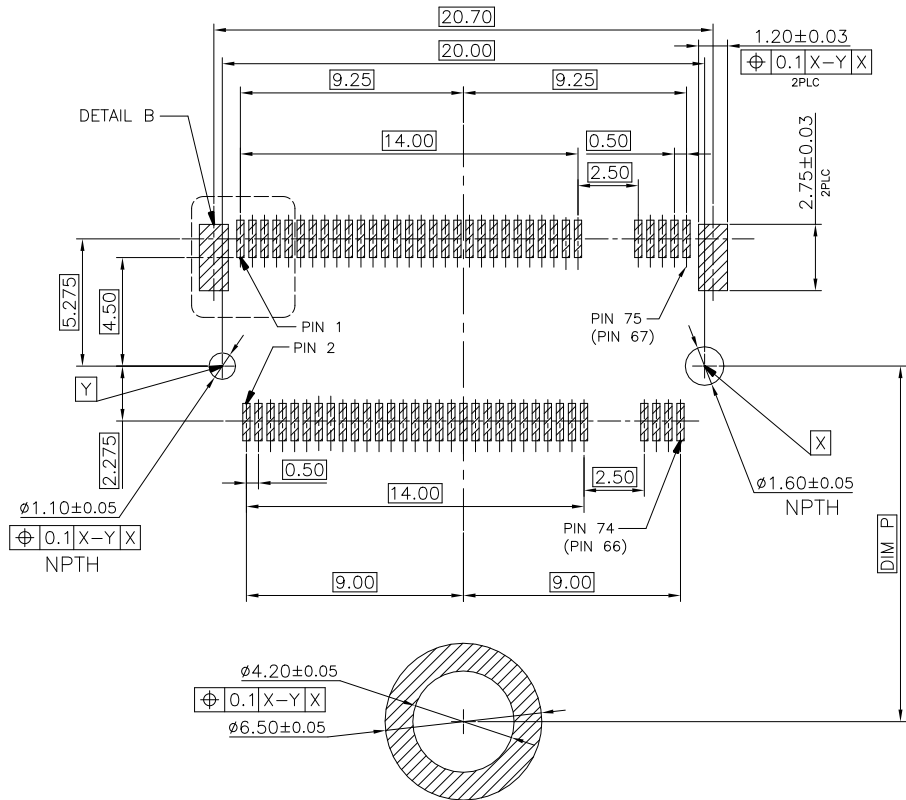

22110	108.25
2280	78.25
2260	58.25
2242	40.25
2230	28.25
3042	40.25
3030	28.25
MODULE TYPE	DIM P

DIM	TOL	DIM	TOL
x.	±0.30	x.	±2*
.x	±0.25	.x	±1*
.xx	±0.15		

**DEREN**  
SHENZHEN DEREN ELECTRONIC CO., LTD

C-DWG:	TY	DATE	TITLE: NGFF 4.80H KEY M STD NO Logo
DESIGN:	Sid Guo	2023.12.14	P/N: SEE TABLE 1
CHECK:	Mike Chen	2023.12.14	SHEET: 2/3
APPROVAL:	Bill Lin	2023.12.14	SCALE: N/A UNIT: mm

REV. A



E

# HF

Halogen Free

EMBOSS WIDTH 44mm, SLOT BACKWARD

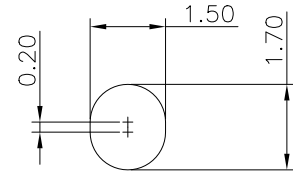
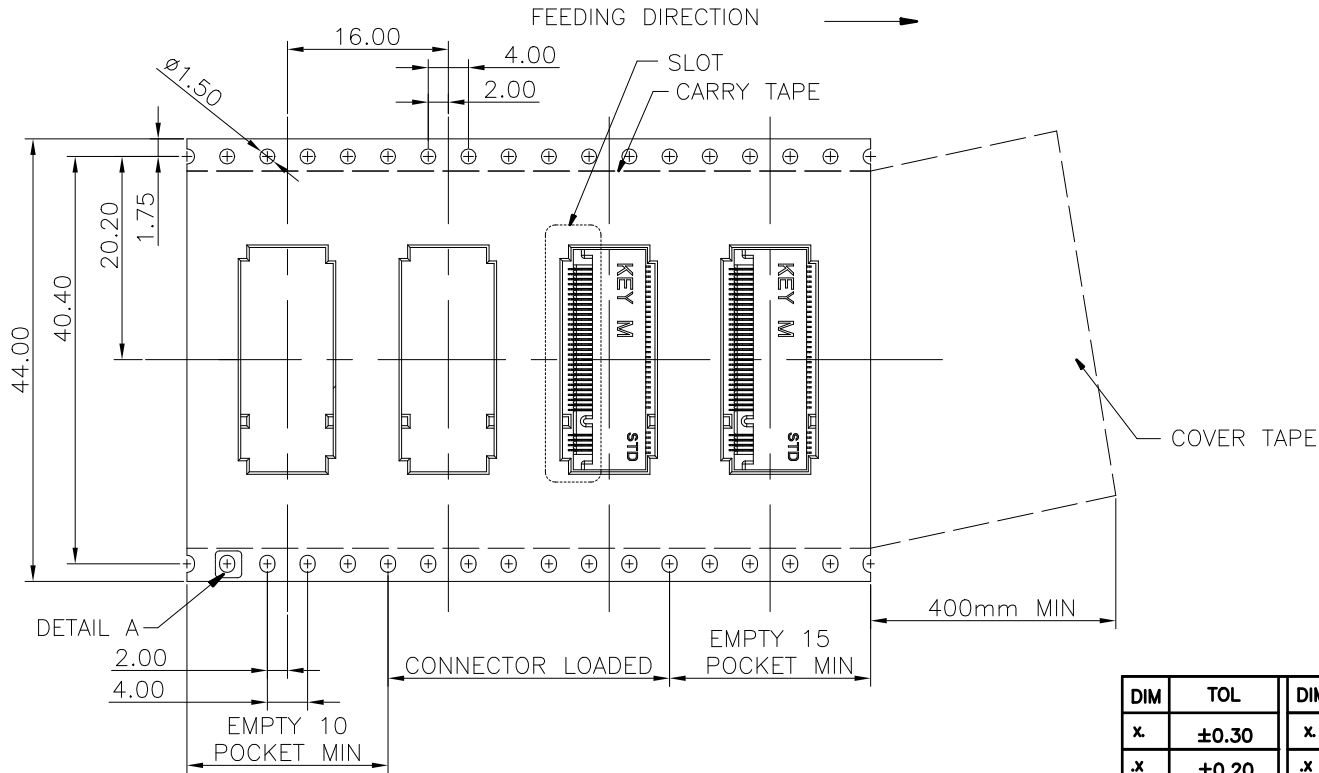
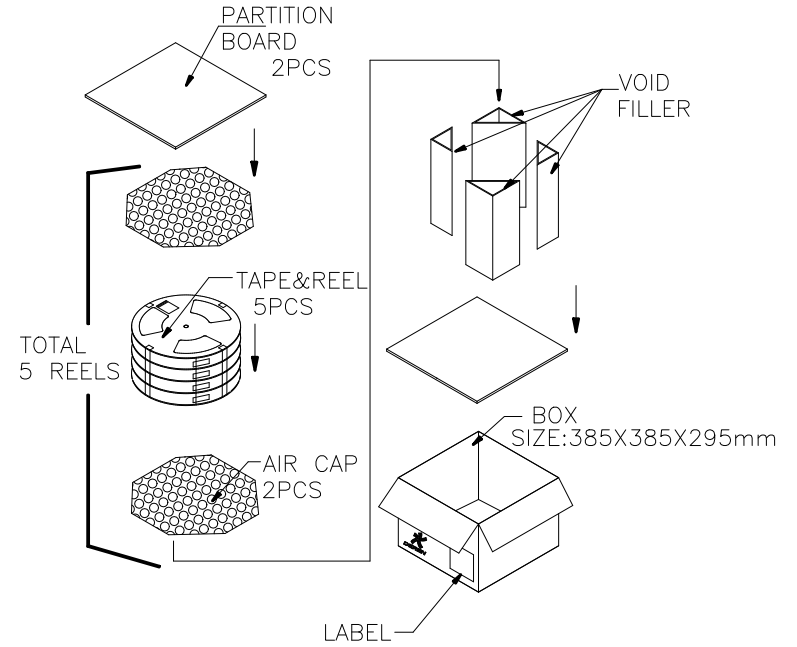
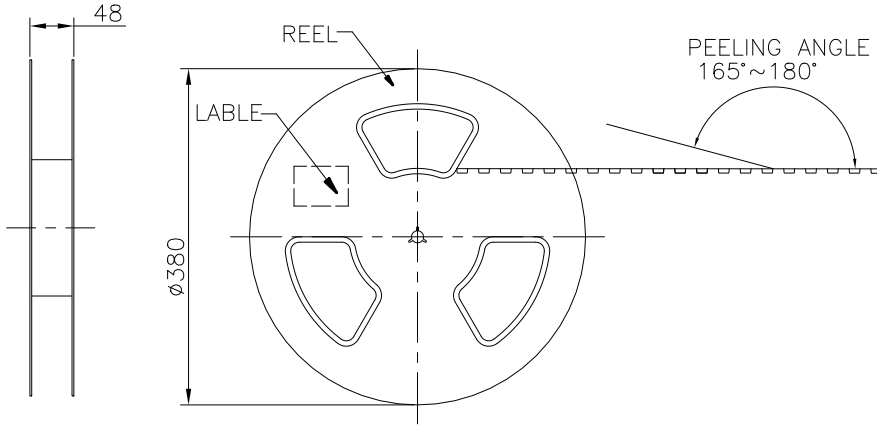

900	5	4500
PCS/REEL	REELS/BOX	PCS/BOX

DIM	TOL	DIM	TOL
x	$\pm 0.30$	x	$\pm 2'$
.x	$\pm 0.20$	.x	$\pm 1'$
.xx	$\pm 0.15$		

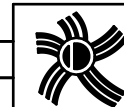

**DEREN**  
SHENZHEN DEREN ELECTRONIC CO., LTD

DRAW NO.  
SC2006910-4

C-DWG: TY DATE  
DESIGN: Sid Guo 2023.12.14  
CHECK: Mike.Chen 2023.12.14

APPROVAL: Bill Lin 2023.12.14

TITLE: NGFF 4.80H KEY M STD NO Logo

P/N: SEE TABLE 1

SHEET: 3/3

SCALE: N/A UNIT: mm