

HF
Halogen Free

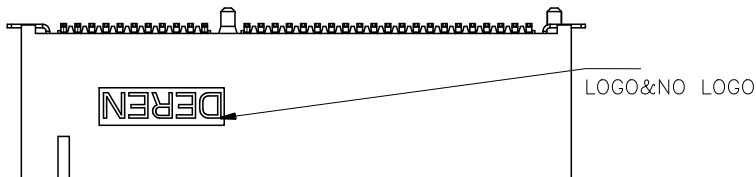
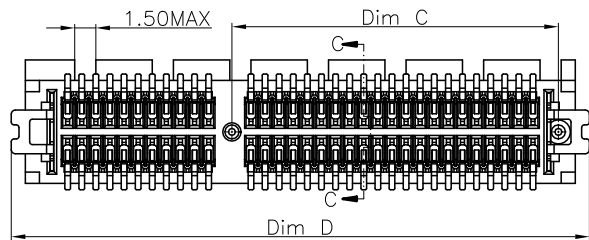
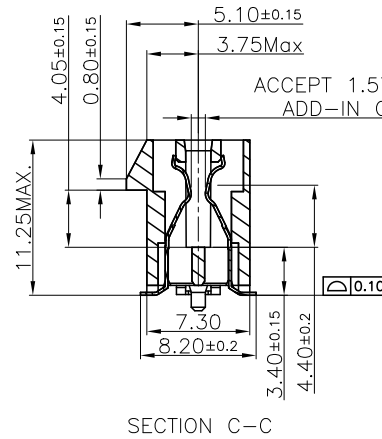
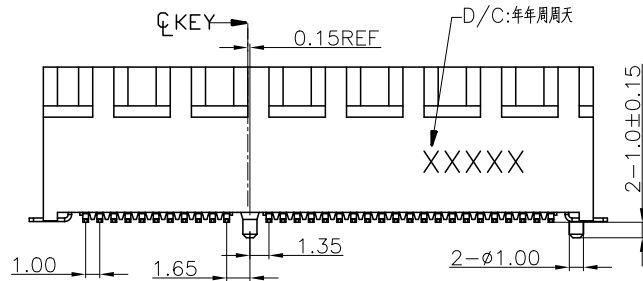
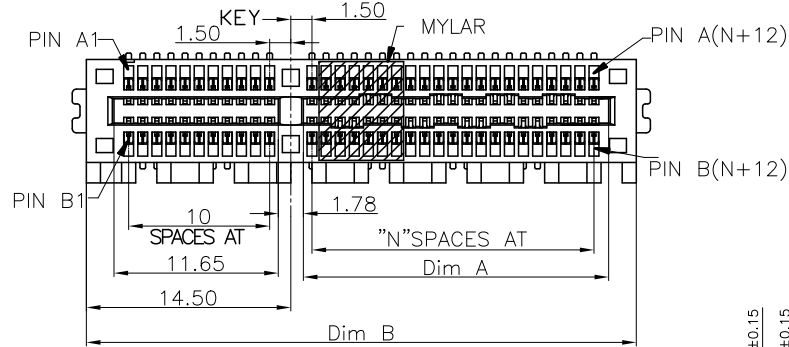

REV.	ECN NO.	LOCATION	DESCRIPTION	DATE	DESIGN
A			INITIAL RELEASE	8/11'23	Cy.Zhu

NOTES:

PRODUCT MEETS CONTROLLED SUBSTANCES SPEC. ROHS 2.0

1. MATERIAL:

- 1.1 HOUSING:HIGH TEMPERATURE PLASTIC UL94V-0; COLOR: BLACK
- 1.2 CONTACT:COPPER ALLOY
- 1.3 PEG: STAINLESS STEEL

2. FINISH:

- CONTACT:GOLD PLATING(SEE PART NUMBER) ON CONTACT AREA.
- 2.54um[100u"] MIN. MATTE-TIN PLATING ON SOLDER TAIL AREA.
- 1.27um[50u"] MIN. NICKEL UNDERPLATING OVERALL.
- PEG:2.54um[100u"] MIN. TIN PLATING OVERALL.
- 1.27um[50u"] MIN. NICKEL UNDERPLATING OVERALL.

3.DATE CODE : YYWWD (YY: YEAR, WW: WEEK, D: DAY)

4.PART NUMBER DESCRIPTION:

564ZD4 - 0 0 5 H * * 0 * *

- PACKING CODE: 1:TRAY 4:TRAY&MYLAR
- 2:REEL 5:HARD TRAY&MYLAR
- 3:HARD TRAY
- HOUSING COLOR: 1:BLACK 2:WITHE 3:BLUE
- 4:BLACK&NO LOGO
- 5:WITHE&NO LOGO
- 6:BLUE&NO LOGO
- RESERVED
- RIDGE&POS CODE: 1.36P&WITH RIDGE
- 2.36P&WITHOUT RIDGE
- 3.64P&WITH RIDGE
- 4.64P&WITHOUT RIDGE
- 5.98P&WITH RIDGE
- 6.98P&WITHOUT RIDGE
- PLATING CODE: 1: G/F
- 2: 15u" Min
- 3: 30u" Min
- HALOGEN CODE: H: HALOGEN FREE

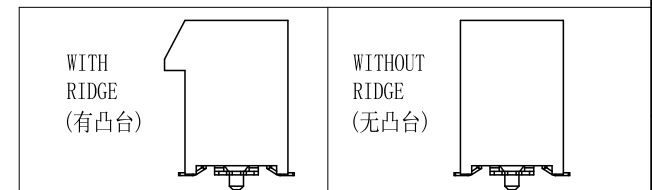

DEREN

SHENZHEN DEREN ELECTRONIC CO., LTD

P/N:	# POS REF	N	DIM A	DIM B	DIM C	DIM D
564ZD4-005H**0**	36	6	7.65	25.00	9.15	27.00
564ZD4-005H**0**	64	20	21.65	39.00	23.15	41.00
564ZD4-005H**0**	98	37	38.65	56.00	40.15	58.00

DIM	TOL	DIM	TOL
.x	±0.30	.x	±2*
.x	±0.25	.x	±1*
.xx	±0.20		

DWG NO. SC2007079

DESIGN: Cy.Zhu 10/20'23

CHECK: MIKE.CHEN 10/20'23

APPROVAL: Bill.Lin 10/20'23

TITLE: PCI EXPRESS 4.0 SMT TYPE

P/N: SEE TABLE

SHEET: 1/4

SCALE: 1:1 UNIT: mm

HF
Halogen Free

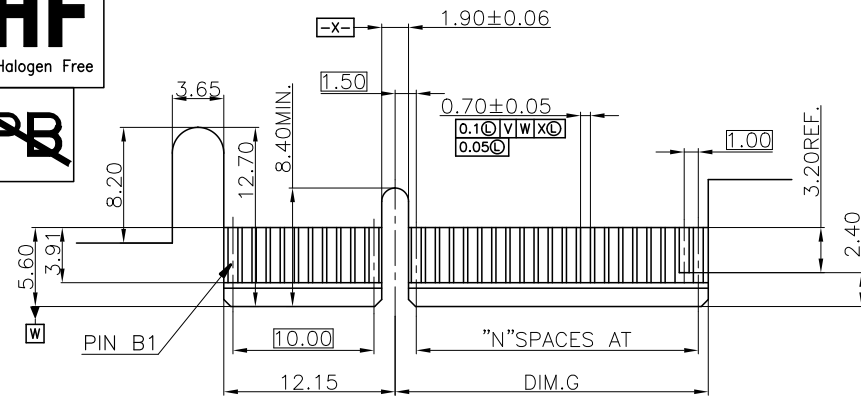

Recommended GOLD FINGER(B SIDE VIEW)

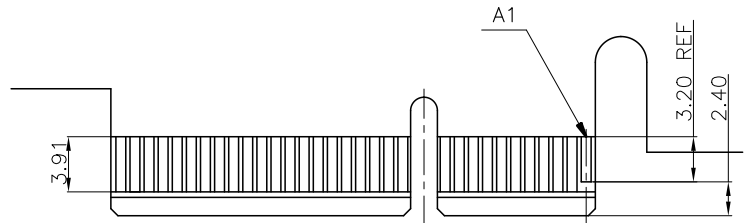

Recommended GOLD FINGER(A SIDE VIEW)

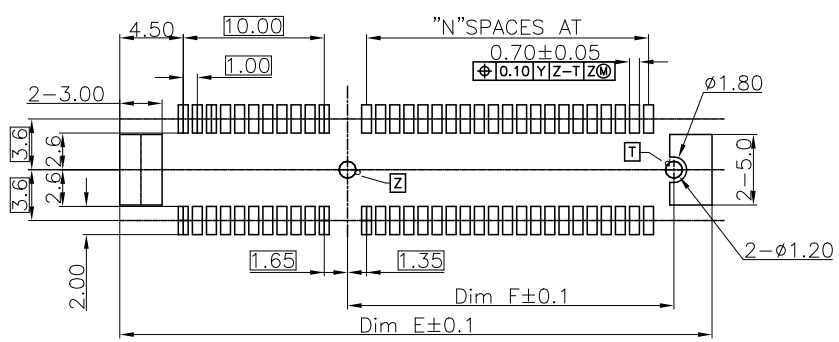

SOLDER PAD RECOMMEND P.C.B LAYOUT (COMPONENT SIDE)
DEFAULT TOLERANCES: ±0.05; PCB THICKNESS: 1.2mm

ACROSS PADS

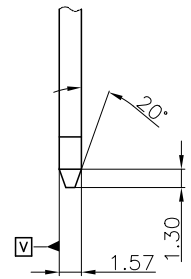

PIN "C"
SEE TABLE

NOTES:

- NO TIE PERMITTED FROM CARD EDGE TO LEADING EDGE OF PAD FOR PINS A1 AND "C"
- CHAMFER EDGES MUST BE FREE OF CUTTING BURRS
- 1. ELECTRICAL CHARACTERISTICS:
 - 1-1. CURRENT RATING: 1.1 AMP. 30°C RISE ABOVE AMBIENT.
 - 1-2. CONTACT RESISTANCE: 30 MILLIOHMS MAX. INITIAL, 50 MILLIOHMS MAX. AFTER TEST.
 - 1-3. INSULATION RESISTANCE: 1000 MEGOHMS MIN. MIN. AT SEA LEVEL.
 - 1-4. DIELECTRICAL WITHSTAND VOLTAGE: 500V AC
- 2. MECHANICAL CHARACTERISTICS:
 - 2-1. INSERTION FORCE: 1.15N MAX. PER CONTACT PAIR.
 - 2-2. REMOVAL FORCE: 0.15N MIN. PER CONTACT PAIR
 - 2-3. DURABILITY: 50 MATING AND UNMATING CYCLES.
 - 2-4. CONTACT RETENTION FORCE: 0.5N MIN.
- 3. ENVIRONMENTAL CHARACTERISTICS:
 - 3-1. OPERATING TEMPERATURE RANGE: -40°C TO +105°C.

贴MYLAR示意图

用REEL装须贴上MYLAR

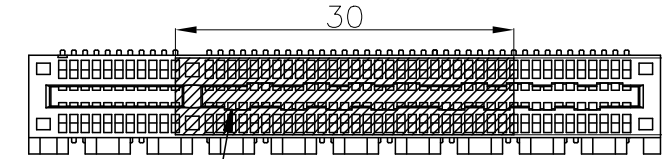

用TRAY装见料号是否贴上MYLAR

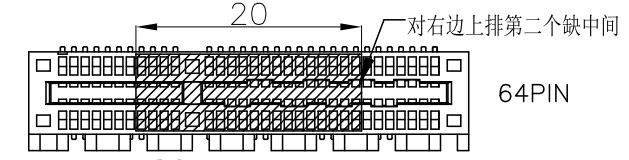

64PIN

用HARD TRAY装见料号是否贴上MYLAR

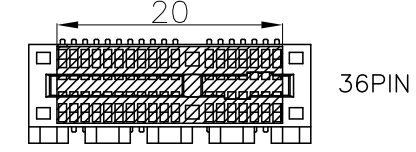

36PIN

# POS REF	N	DIM E	DIM F	DIM G	PIN C
36	6	28.00	9.15	8.15	B17
64	20	42.00	23.15	22.15	B31
98	37	59.00	40.15	39.15	B48



DEREN

SHENZHEN DEREN ELECTRONIC CO., LTD

DIM	TOL	DIM	TOL
.x	±0.30	.x	±2*
.x	±0.25	.x	±1*
.xx	±0.20		

DWG-C
DESIGN: Cy.Zhu
CHECK: MIKE.CHEN
REV. A

DATE: 8/11'23
DATE: 8/11'23
DATE: 8/11'23

TITLE: PCI EXPRESS 4.0 SMT TYPE
P/N: SEE TABLE
SHEET: 2/4
SCALE: 1:1
UNIT: mm

HF
Halogen Free

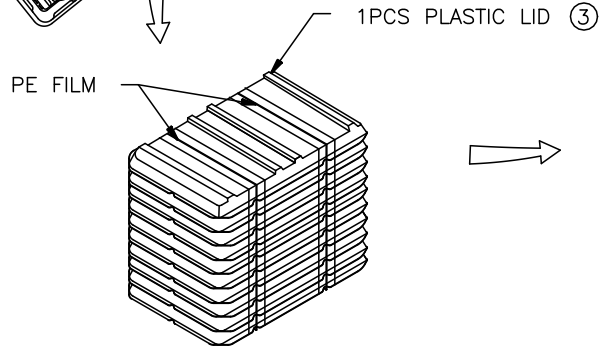
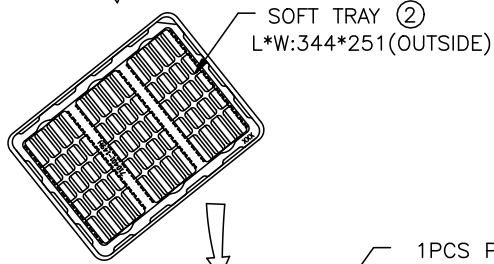
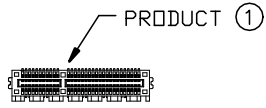

5	CARTON	50-41001-18	360*270*315mm(INNER)	1
4	BAG	55-41009-01	750*600*0.05mm	1
3	LID	-	344*251mm	1
2	SOFT TRAY	-	344*251mm	20
1	CONN	-	-	SEE TABLE
NO.	PART NAME	PART NUMBER	SPEC.	QTY

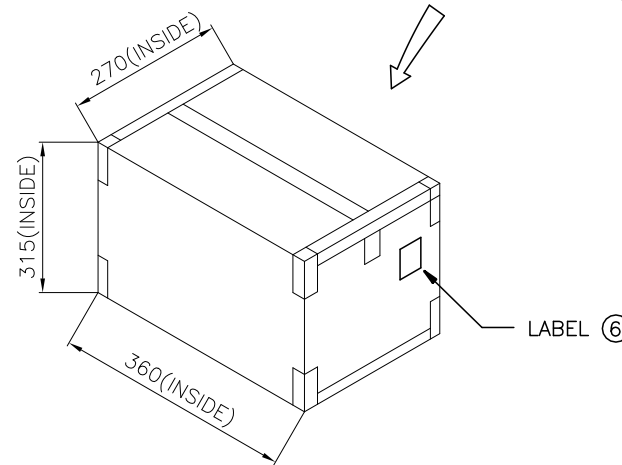
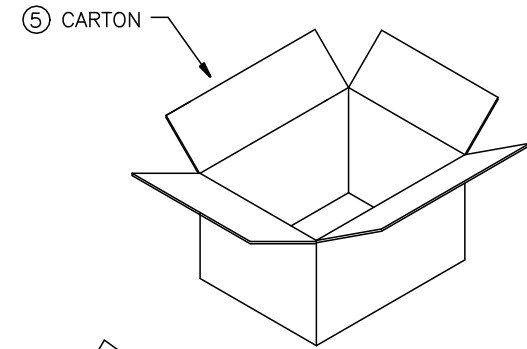
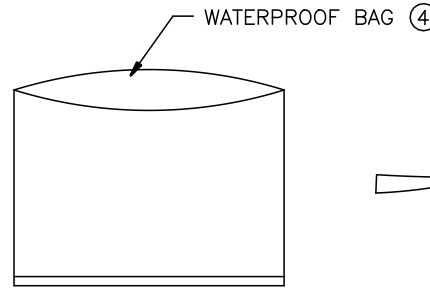

NOTE:

1. PUT THE PRODUCTS INTO TRAY WITH DIRECTION AS THE LEFT SKETCH SHOWN, Q'TY SEE TABLE, 12 TRAYS STACKED UP PER BUNDLE. THEN ADD AN EMPTY TRAY ON TOPSIDE.
2. WIND THE TWO ENDS WITH PE FILM.
3. PUT THE PRODUCTS BUNDLED INTO WATER-PROOF PE BAG, 1 BUNDLES/BAG, THEN PUT INTO THE CARTON.
4. SEAL OUTER CARTON WITH PACKING TAPE LIKE A 'H' SHAPE.
5. PACKAGING QUANTITY: SEE TABLE.

P/N:	#POS REF	RIDGE	PCS/ROW OF TRAY	PCS/COLUMN OF TRAY	PCS/TRAY	TRAYS/CARTON	PCS/CARTON
564ZD4-005H*10*1	36	WITH	15	8	120	20	2400
564ZD4-005H*20*1		WITHOUT	15	8	120	20	2400
564ZD4-005H*30*1	64	WITH	15	6	90	20	1800
564ZD4-005H*40*1		WITHOUT	15	6	90	20	1800
564ZD4-005H*50*1	98	WITH	15	4	60	20	1200
564ZD4-005H*60*1		WITHOUT	15	4	60	20	1200

DIM	TOL	DIM	TOL
x	±0.30	.x	±2*
.x	±0.25	.x	±1*
.xx	±0.20		

		DEREN SHENZHEN DEREN ELECTRONIC CO., LTD		TITLE: PCI EXPRESS 4.0 SMT TYPE	
				DRAW NO. SC2007079	
DWG-C	TY	DATE	DESIGN: Cy.Zhu	8/11'23	
CHECK: MIKE.CHEN	8/11'23	APPROVAL: Bill.Lin	8/11'23	SHEET: 3/4	
REV. A	SCALE: N/A	UNIT: mm			

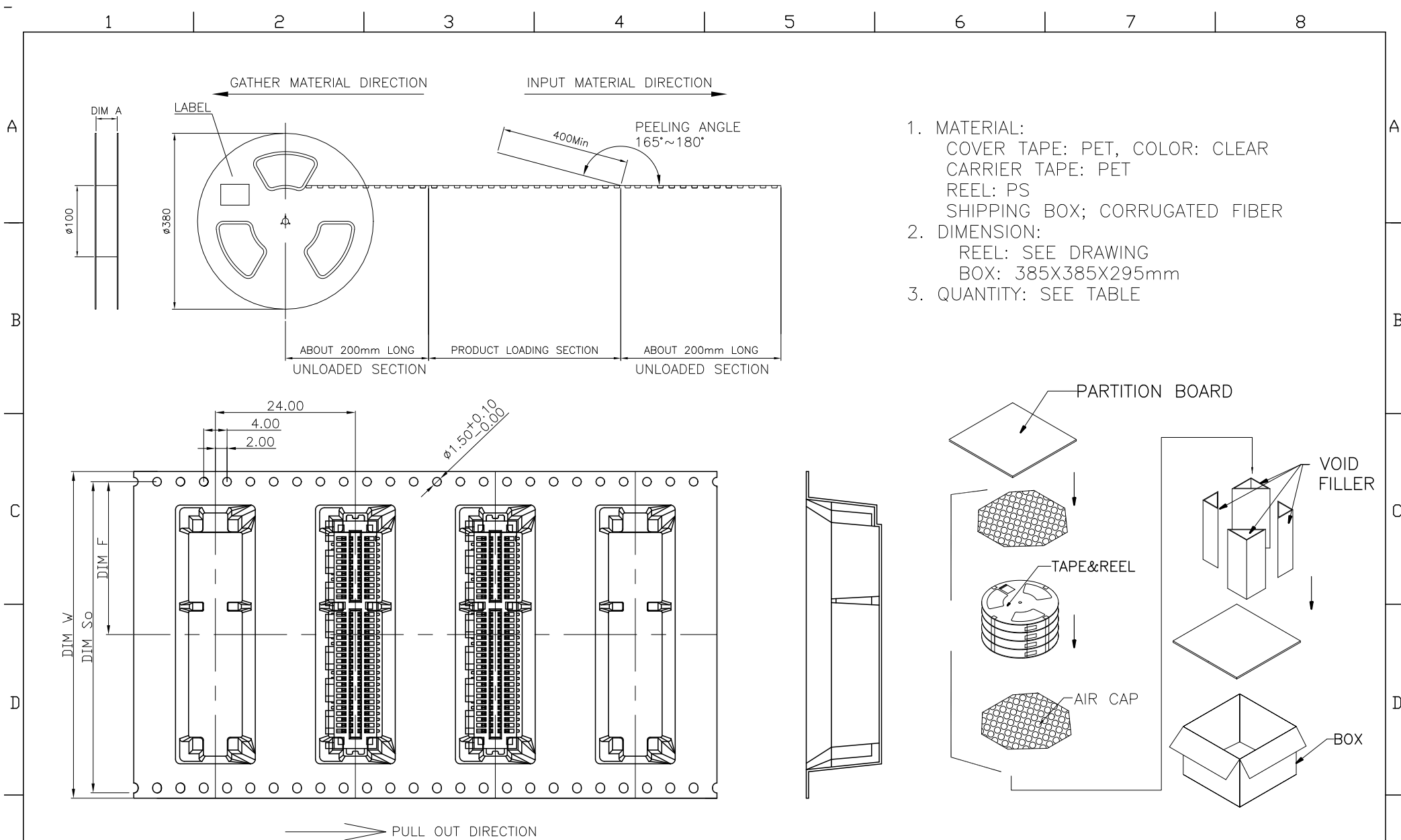

1. MATERIAL:
COVER TAPE: PET, COLOR: CLEAR
CARRIER TAPE: PET
REEL: PS
SHIPPING BOX; CORRUGATED FIBER
2. DIMENSION:
REEL: SEE DRAWING
BOX: 385X385X295mm
3. QUANTITY: SEE TABLE

P/N:	#POS REF	RIDGE	DIM W	DIM SO	DIM F	DIM A/ REEL	PCS/ REEL	REELS/ CARTON	PCS/ CARTON
564ZD4-005H**0*2	36	WITH	44	40.4	20.2	44.4	300	5	1500
564ZD4-005H**0*2	64	WITH	56	52.4	26.2	56.4	300	4	1200
564ZD4-005H**0*2	98	WITH	72	68.4	34.2	72.4	300	3	900

DIM	TOL	DIM	TOL
.x	±0.30	.x	±2'
.x	±0.25	.x	±1'
.xx	±0.20		

 DEREN SHENZHEN DEREN ELECTRONIC CO., LTD		DWG-C	TY	DATE	TITLE: PCI EXPRESS 4.0 SMT TYPE	
		DESIGN:	Cy.Zhu	8/11'23	P/N: SEE TABLE	
DRAW NO. SC2007079		CHECK:	MIKE.CHEN	8/11'23	SHEET: 4/4	
REV. A	APPROVAL:	Bill.Lin	8/11'23	SCALE: N/A	UNIT: mm	