

HF

Halogen Free

| REV. | ECN NO. | LOCATION | DESCRIPTION | DATE | DESIGN |
|------|---------|----------|-----------------|------------|---------|
| A | | | INITIAL RELEASE | 2023.11.15 | Sid Guo |

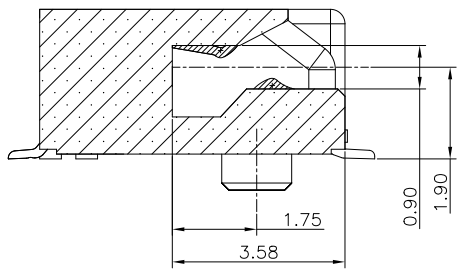
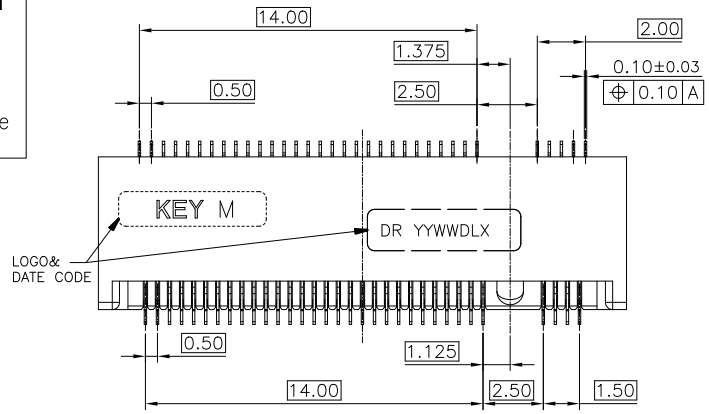

- NOTES:
- MATERIAL:
 - HOUSING:HIGH TEMPERATURE THERMOPLASTIC, UL94V-0,COLOR:BLACK.
 - CONTACT:COPPER ALLOY.
 - SOLDER PEG:STAINLESS STEEL.
 - FINISH:
 - CONTACT:UNDERPLATING NICKEL 50u" MIN ALL OVER. MATING AREA:GOLD PLATING, THICKNESS SEE TABLE LIST. SOLDER AREA:GOLD FLASH ON SOLDER TAIL.
 - SOLDER PEG:UNDERPLATING NICKEL 50u" MIN ALL OVER,80u" MIN MATTE TIN ON SURFACE
 - LOGO&DATE CODE :LOGO: DR LOGO, DATE CODE: YYWDLX
 YY: YEAR (09: 2009)
 WW: WEEK (25: THE 25TH WEEK)
 D: DAY (1~7: SUNDAY~SATURDAY)
 L: LINE NUMBER OF ASSEMBLY (A: LINE A)
 X: MANUFACTURE CODE
 - RECOMMENDE STENCIL THICKNESS .012MM MIN
 - CONNECTOR ACTUAL PIN QUANTITY IS 67, AS THE KEY TAKING OUT 8 PINS.

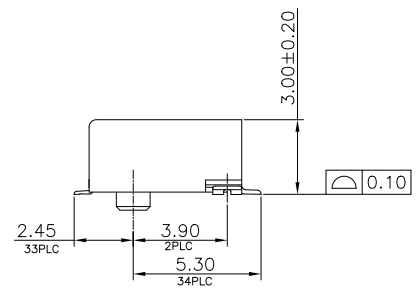
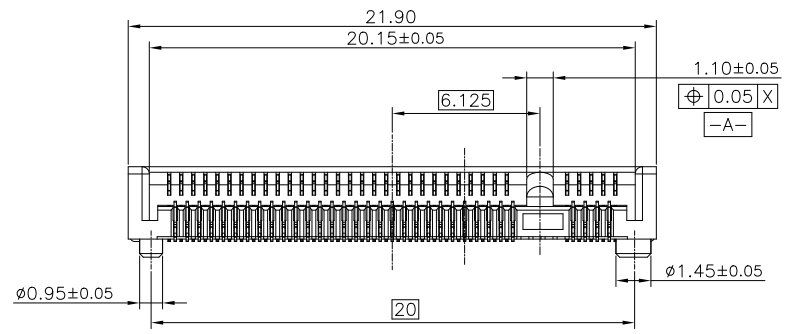

562136-0 0 X H 0 1 1 R

PACKAGE CODE:
R: EMBOSS WIDTH 44mm, SLOT BACKWARD

Logo: 0: No Logo
1: DR Logo

Color:
1:Black
2:White
Reserved

HALOGEN CODE:
H:HALOGEN FREE

PLATING CODE:
1: AuGF 2: Au5u"
3: Au10u" 4: 15u"
5: Au30u"

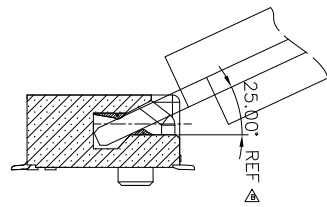
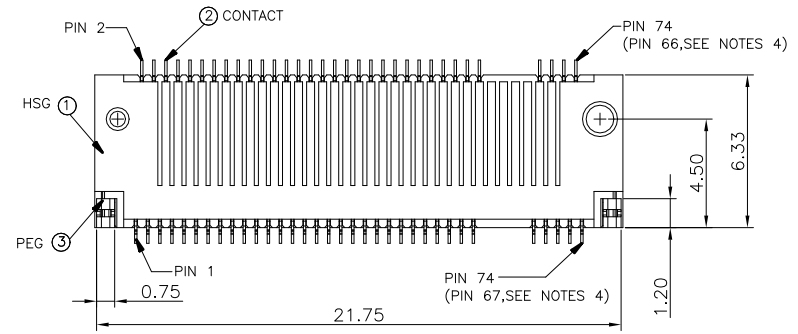



TABLE 1:

| PART NUMBER | DESCRIPTION |
|-----------------|-------------------------|
| 562136-001H011R | Au G/F ON CONTACT AREA |
| 562136-002H011R | Au 5u" ON CONTACT AREA |
| 562136-003H011R | Au 10u" ON CONTACT AREA |
| 562136-004H011R | Au 15u" ON CONTACT AREA |
| 562136-005H011R | Au 30u" ON CONTACT AREA |

| DIM | TOL | DIM | TOL |
|------|-------|-----|-----|
| x. | ±0.30 | x. | ±2* |
| .x | ±0.25 | .x | ±1* |
| .xxx | ±0.05 | | |



DEREN
SHENZHEN DEREN ELECTRONIC CO., LTD

| | | | |
|----------------------|------------------|------------|----------------------------|
| C-DWG | TY | DATE | TITLE:NGFF 3.2H Key M GEN4 |
| DRAW NO. SC2208387-2 | DESIGN: Sid Guo | 2023.11.15 | P/N: SEE TABLE 1 |
| REV. A | CHECK: Mike Chen | 2023.11.15 | SHEET: 1/3 |
| APPROVAL: Bill Lin | 2023.11.15 | SCALE: N/A | UNIT: mm |

HF

Halogen Free

PLUG PCB

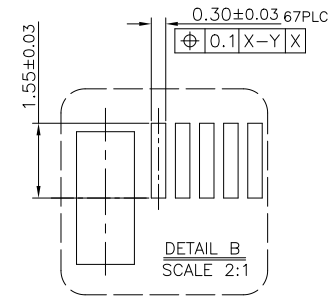
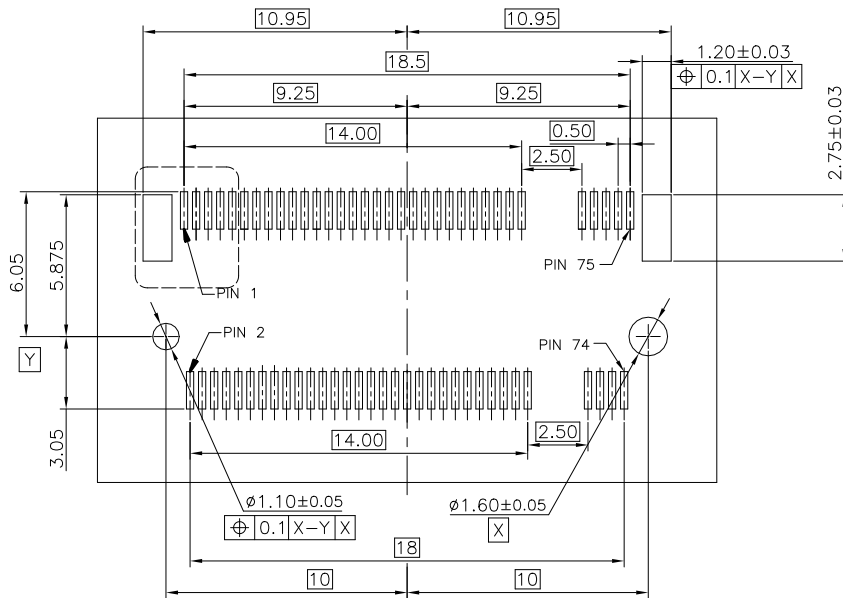
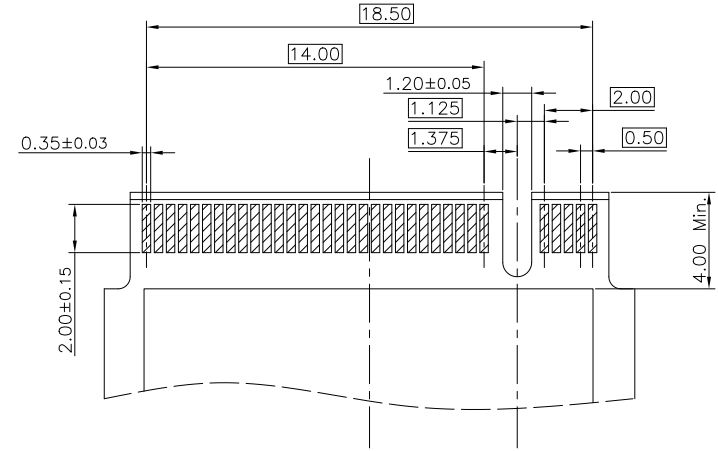
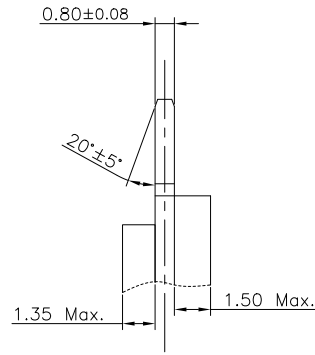
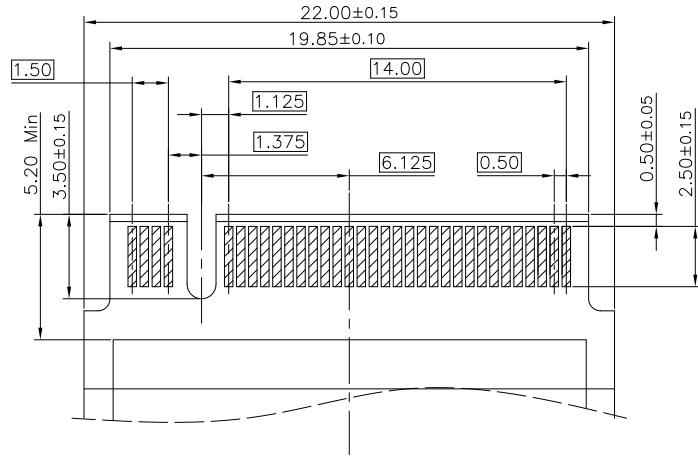

| | |
|-------------|--------|
| 22110 | 108.25 |
| 2280 | 78.25 |
| 2260 | 58.25 |
| 2242 | 40.25 |
| 2230 | 28.25 |
| 3042 | 40.25 |
| 3030 | 28.25 |
| MODULE TYPE | DIM P |

RECOMMEDNED NGFF PCB LAYOUT(TOP VIEW)

| DIM | TOL | DIM | TOL |
|------|-------|-----|-----|
| .x | ±0.30 | .x | ±2° |
| .x | ±0.25 | .x | ±1° |
| .xx | ±0.15 | | |
| .xxx | ±0.05 | | |



DEREN
SHENZHEN DEREN ELECTRONIC CO., LTD

| | | | |
|-----------|-------------|------------|----------------------------|
| C-DWG | TY | DATE | TITLE:NGFF 3.2H Key M GEN4 |
| DESIGN: | Sid Guo | 2023.11.15 | P/N: SEE TABLE 1 |
| CHECK: | Mike Chen | 2023.11.15 | SHEET: 2/3 |
| APPROVAL: | Bill Lin | 2023.11.15 | SCALE: N/A UNIT: mm |
| DRAW NO. | SC2208387-2 | REV. A | |

HF

Halogen Free

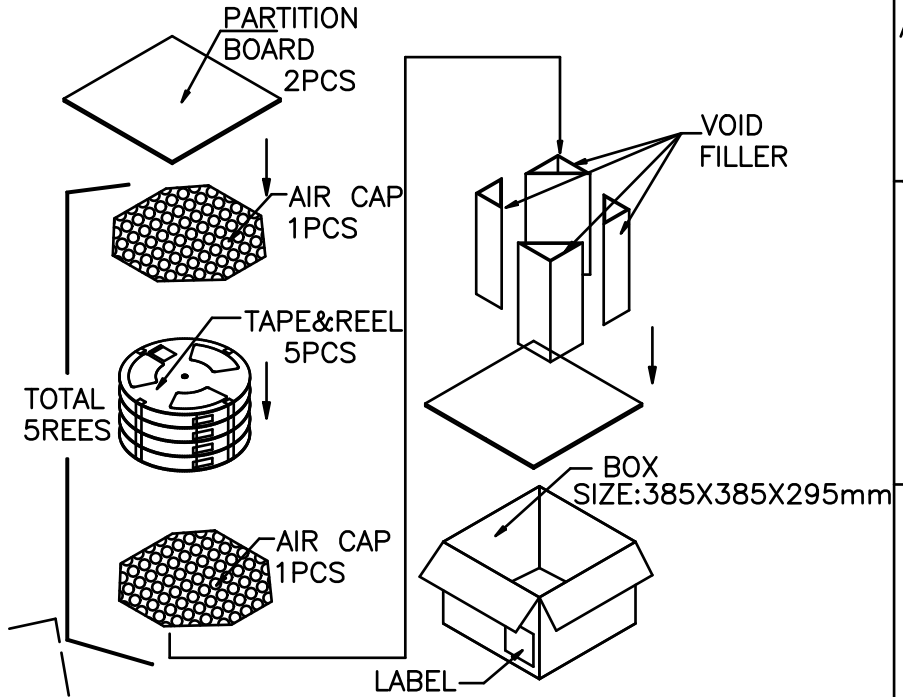
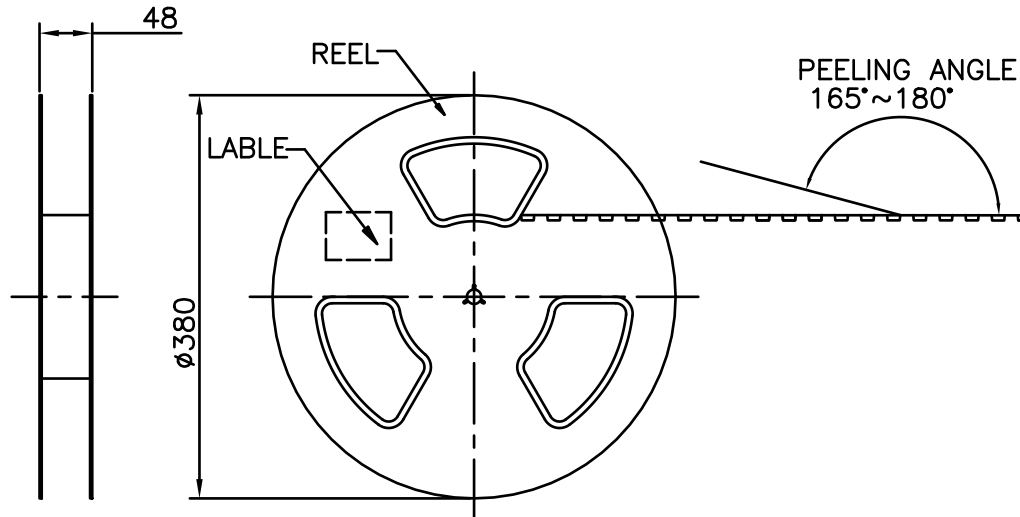

FEEDING DIRECTION →

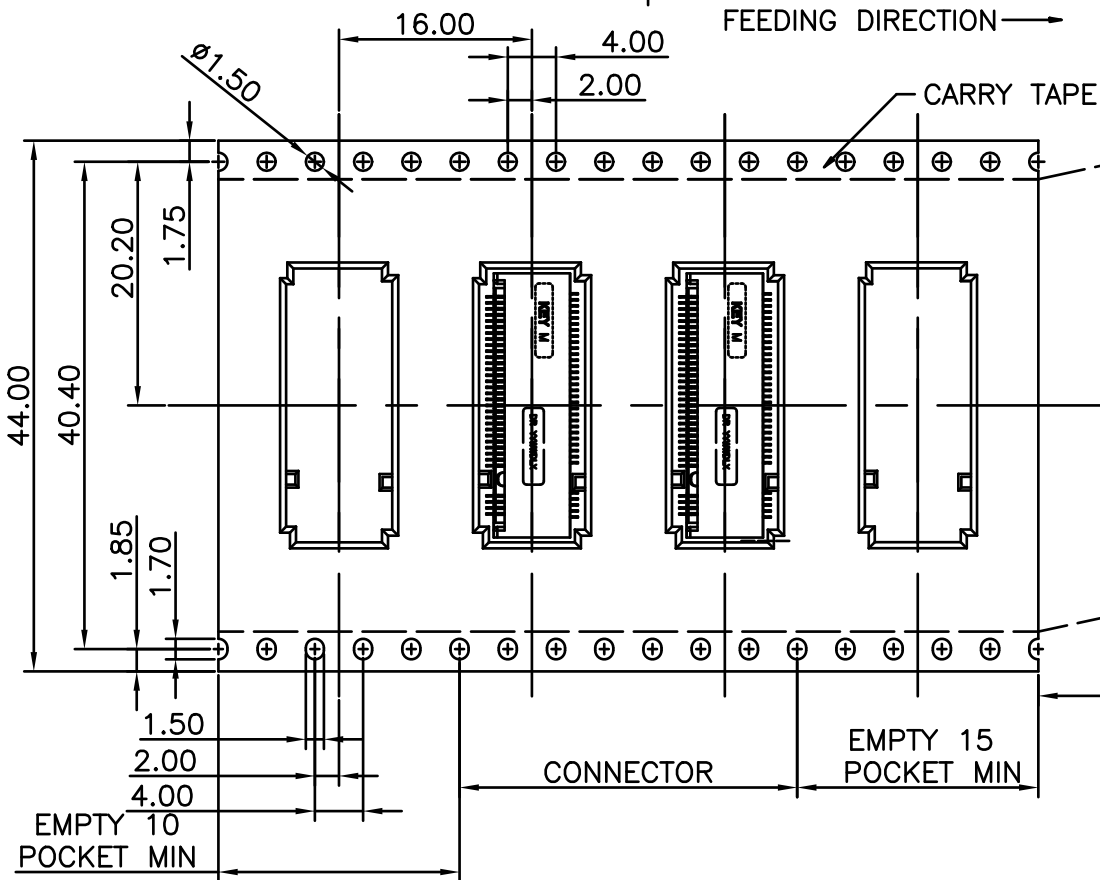

| | | |
|----------|-----------|---------|
| 1400 | 5 | 7000 |
| PCS/TAPE | REELS/BOX | PCS/BOX |

400mm MIN

| DIM | TOL | DIM | TOL |
|------|-------|-----|-----|
| .x | ±0.30 | .x | ±2' |
| .x | ±0.25 | .x | ±1' |
| .xx | ±0.15 | | |
| .xxx | ±0.05 | | |

DEREN
SHENZHEN DEREN ELECTRONIC CO., LTD

| | | |
|-----------|-----------|------------|
| C-DWG | TY | DATE |
| DESIGN: | Sid Guo | 2023.11.15 |
| CHECK: | Mike Chen | 2023.11.15 |
| APPROVAL: | Bill Lin | 2023.11.15 |

TITLE: NGFF 3.2H Key M GEN4

P/N: SEE TABLE 1

SHEET: 3/3

SCALE: N/A **UNIT:** mm

EMPTY 10 POCKET MIN

CONNECTOR

EMPTY 15 POCKET MIN

DRAW NO. SC2208387-2

REV. A