

HF

Halogen Free

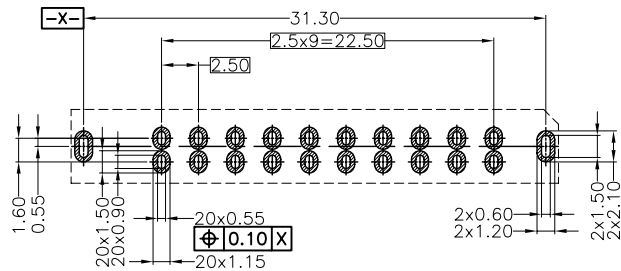
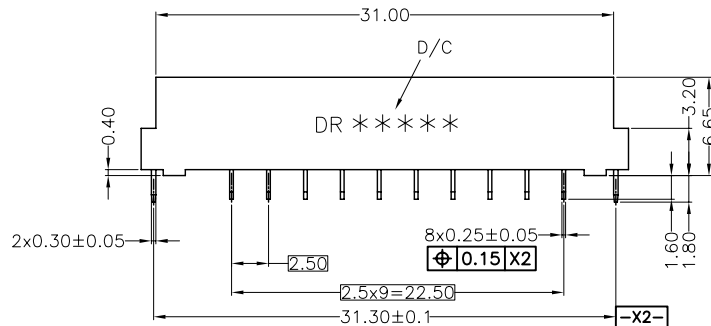
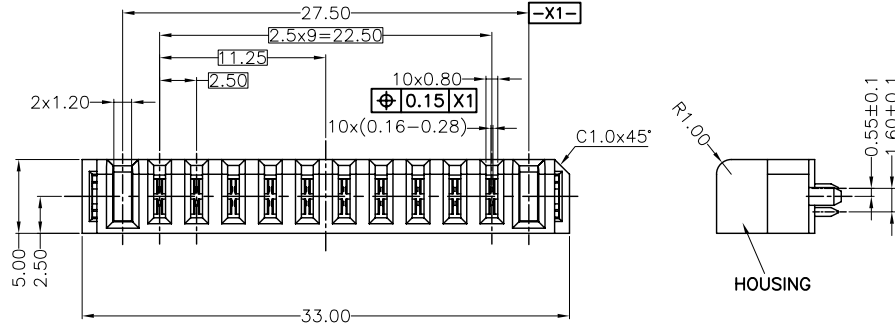
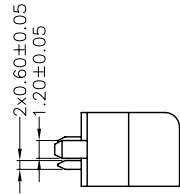
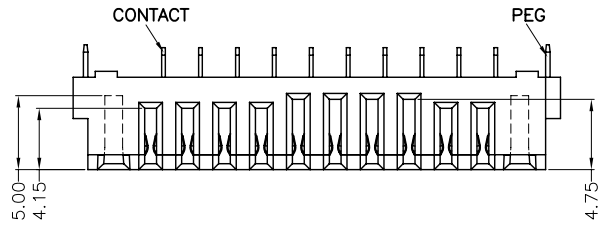

RECOMMENDED P.C.B LAYOUT
TOLERANCE: ±0.05mm

REV.	ECN NO.	LOCATION	DESCRIPTION	DATE	DESIGN
1			PRELIMINARY	04/05'2016	Mike.Chen
2			UPDATE STAND OFF HEIGHT	04/09'2016	Mike.Chen
3			CHANGE CONTACT	09/09'2016	Mike.Chen
4			ADD GAP SPEC	09/27'2016	Mike.Chen

NOTES :**1. MATERIAL :**

1.1 HOUSING: HIGH TEMPERATURE THERMOPLASTIC,
BLACK, UL94 V-0,

1.2 CONTACTS: COPPER ALLOY T=0.25mm,

1.3 PEG: BRASS T=0.30mm

2. FINISH :**2.1 CONTACT**

Au PLATING ON THE CONTACT AREA,

80u"MIN MATTE-TIN PLATING ON THE SOLDER AREA.

50u"MIN NICKEL UNDERPLATING OVER ALL.

3. DATE CODE : YYWWD

YY: YEAR (15: 2015)

WW: WEEK (25: THE 25TH WEEK)

D: (1~7: SUNDAY~SATURDAY)

4. DURABILITY: 1000 CYCLES**5. PART NUMBER DESCRIPTION :**

40 - 42557 - 010 1 2 R HF - DJ

CUSTOMER CODE

HF: HALOGEN FREE

PACKAGE CODE:

R=TAPE REEL

PLATE CODE: 1=GOLD FLASH

2=Au 5u"

3=Au 10u"

4=Au 15u"

5=Au 30u"

LOGO

0:NO LOGO

1:DEREN LOGO

PIN NUMBER: 010=10 PINS

DIM	TOL	DIM	TOL
x.	±0.25	x.	±2°
.x	±0.20	.x	±1°
.xx	±0.15		

**DEREN**

SHENZHEN DEREN ELECTRONIC CO., LTD

CUSTOMER DRAWING		DATE		TITLE: BATTERY 10PIN REC	
DESIGN:	Mike.Chen	09/27'2016		P/N: 40-42557-01012RHF-DJ	
CHECK:	DONGMAOJIE	09/27'2016		SHEET:	1/2
APPROVAL:	Richard.Peng	09/27'2016		SCALE:	N/A
REV.	4			UNIT:	mm

1 2 3 4 5 6 7 8

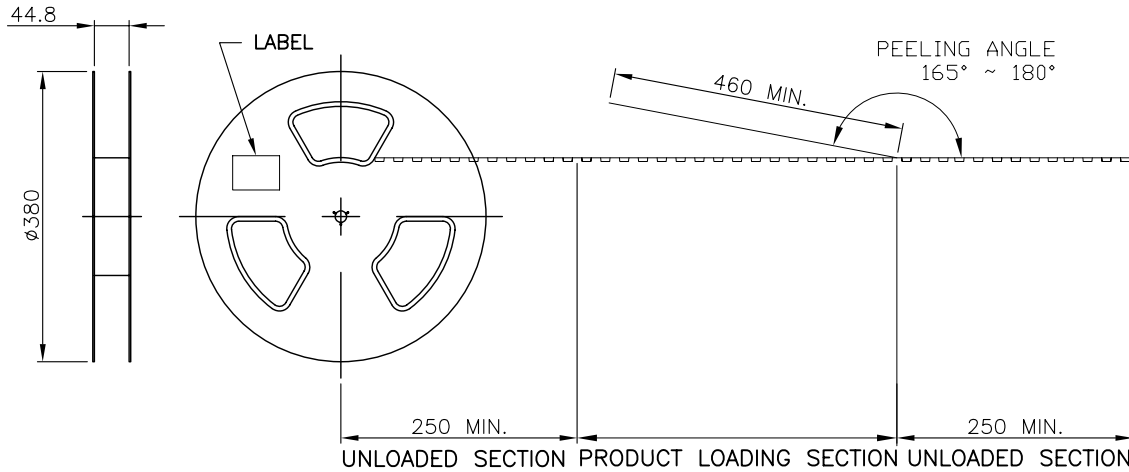

NOTES :

- MATERIAL :
 COVER TAPE : P.S T=0.05
 CARRIER TAPE : P.S T=0.40
 REEL : PS UL94V-0
 CARTON: CORRUGATED FIBER
- DIMENSION :
 REEL : SEE DRAWING
 SHIPPING BOX: 395X395X250mm
- QUANTITY : SEE TABLE
- PEELING RESISTANCE : 10gf~130gf (for 12~56mm)
- PEELING SPEED : 300mm/MINUTES

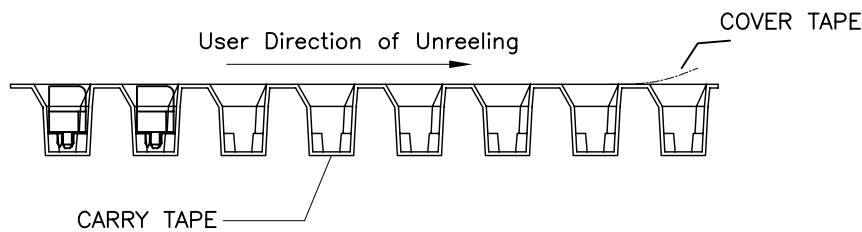
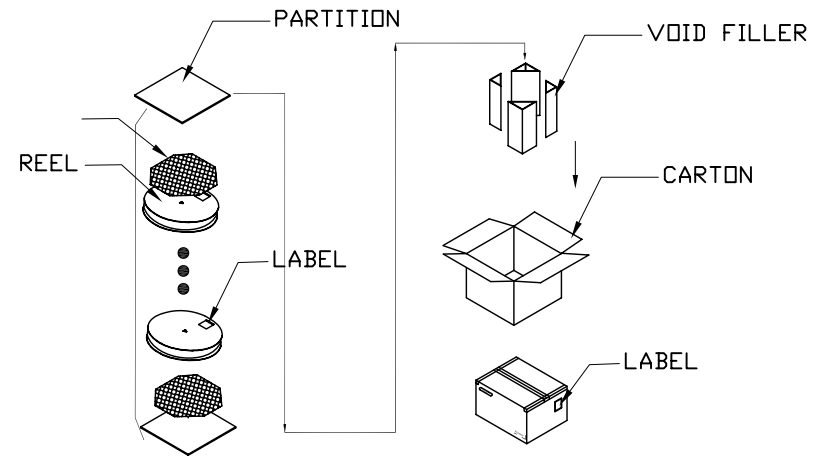
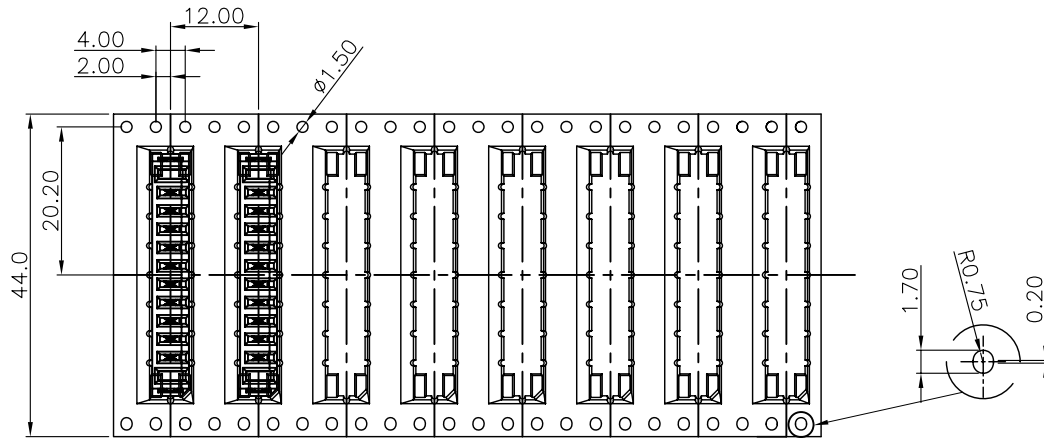

800	5	4000
PCS/REEL	REEL/BOX	TOTAL Q'TY

DIM	TOL	DIM	TOL
.x		.x	
.x		.x	
.xx			
.xxx			

	DEREN SHENZHEN DEREN ELECTRONIC CO., LTD		
	CUSTOMER DRAWING	DATE	TITLE: BATTERY 10PIN REC
	DESIGN: Mike.Chen	09/27'2016	P/N: 40-42557-01012RHF-DJ
	CHECK: DONGMAOJIE	09/27'2016	SHEET: 2/2
REV. 4	APPROVAL: Richard.Peng	09/27'2016	SCALE: N/A UNIT: mm